

**Angle Heads - Monoblock and Modular  
for CNC Machining Centers**

**Monoblock**

Pages 188-241

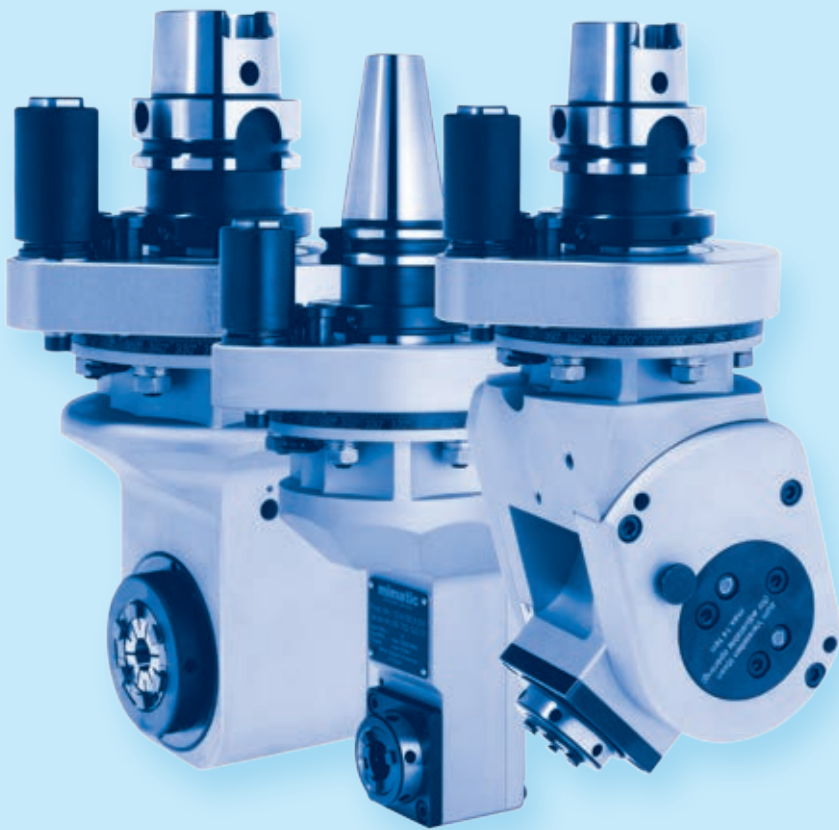

**Modular**

Pages 242-259

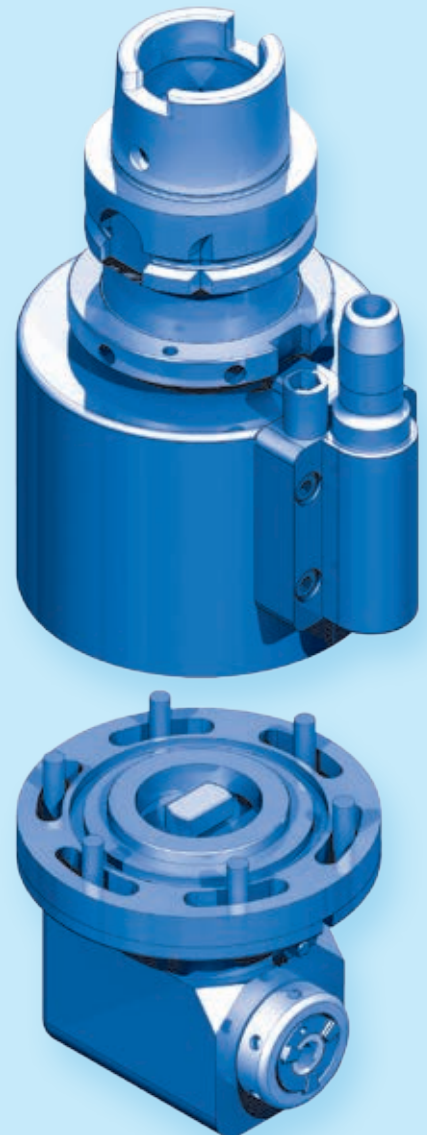

# Table of Contents – Monoblock Angle Heads

Connectable in accordance with **BLUECOMPETENCE** » mimatic mi » PolyMILL » TriMILL » PolyREAM

## DIN 69871

**Selection by  
Clearance Diameter E  
and  
Milling Depth L<sub>1</sub>**

Angle Head 90°

Double  
Angle Head 90°

Angle Head 90°  
Offset Type

Angle Head 90°  
Offset Slim Type

Angle Head,  
Adjustable 0-98°



SK 40				SW			DW			ZW			ZWS			WS		
Size		Tool holder	Coolant	E Ø mm	L <sub>1</sub> mm	Page	E Ø mm	L <sub>1</sub> mm	Page	E Ø mm	L <sub>1</sub> mm	Page	E Ø mm	L <sub>1</sub> mm	Page	E Ø mm	L <sub>1</sub> mm	Page
0		ER 11											50	38				
1		ER 16	✓	91	80													
3		ER 20	✓										75	80		-	91	
		mi	✓										100	80		-	91	
5		ER 25	✓	110	80	200	125	80	201	103	80	202	82	76	203	-	96	204
		mi	✓	120	80		125	80		103	80		82	76		-	96	
				138	80		200	80		130	80		125	76		-	96	
				146	80		200	80		130	80		125	76		-	96	
7		ER 32	✓	145	80		152	80		128	100							
		mi	✓	155	80		152	80		128	100							
				172	80		220	80		150	100							
				178	80		220	80		150	100							

SK 50				SW			DW			ZW			ZWS			WS		
Size		Tool holder	Coolant	E Ø mm	L <sub>1</sub> mm	Page	E Ø mm	L <sub>1</sub> mm	Page	E Ø mm	L <sub>1</sub> mm	Page	E Ø mm	L <sub>1</sub> mm	Page	E Ø mm	L <sub>1</sub> mm	Page
0		ER 11											50	38				
5		ER 25	✓	110	75		125	70		103	79		82	76		-	96	
		mi	✓	120	75		125	70		103	79		82	76		-	96	
				138	75		200	70		133	79		125	76		-	96	
				146	75		200	70		133	79		125	76		-	96	
7		ER 32	✓	145	75	205	152	70	206	128	94	207	102	100	208	-	108	209
		mi	✓	155	75		152	70		128	94		102	100		-	108	
				172	75		220	70		152	94		135	100		-	108	
				178	75		220	70		152	94		135	100		-	108	
9		ER 40	✓	195	105		210	109		140	152							
		mi	✓	195	105		210	109		140	152							
				224	105		250	109		165	152							
				224	105		250	109		165	152							

# Table of Contents – Monoblock Angle Heads

Connectable in accordance with  
**BLUECOMPETENCE** » mimatic mi  
» PolyMILL » TriMILL » PolyREAM

## DIN 69893 A

Selection by  
Clearance Diameter E  
and  
Milling Depth L<sub>1</sub>

Angle Head 90°



Double  
Angle Head 90°



Angle Head 90°  
Offset Type



Angle Head 90°  
Offset Slim Type



Angle Head,  
Adjustable 0-98°



HSK 63				SW			DW			ZW			ZWS			WS		
Size		Tool holder	Coolant	E Ø mm	L <sub>1</sub> mm	Page	E Ø mm	L <sub>1</sub> mm	Page	E Ø mm	L <sub>1</sub> mm	Page	E Ø mm	L <sub>1</sub> mm	Page	E Ø mm	L <sub>1</sub> mm	Page
0		ER 11											50	38				
1		ER 16		91	80													
			✓	96	80													
3		ER 20											75	80		-	91	
			✓														-	91
5		ER 25		110	80	210	125	80	211	103	80	212	82	76	213	-	96	214
			✓	120	80		125	80		103	80		82	76		-	96	
				138	80		200	80		130	80		125	76		-	96	
			mi	✓	146		80	200		80	130		80	125		76	-	
7		ER 32		145	80		152	80		128	100							
			✓	155	80		152	80		128	100							
				172	80		220	80		150	100							
			mi	✓	178	80		220	80		150	100						

HSK 100				SW			DW			ZW			ZWS			WS		
Size		Tool holder	Coolant	E Ø mm	L <sub>1</sub> mm	Page	E Ø mm	L <sub>1</sub> mm	Page	E Ø mm	L <sub>1</sub> mm	Page	E Ø mm	L <sub>1</sub> mm	Page	E Ø mm	L <sub>1</sub> mm	Page
0		ER 11											50	38				
5		ER 25		110	75		125	70		103	79		82	76		-	96	
			✓	120	75		125	70		103	79		82	76		-	96	
				138	75		200	70		133	79		125	76		-	96	
7		ER 32		145	75	215	200	70	216	133	79	217	125	76	218	-	96	219
			✓	146	75		200	70		133	79		125	76		-	96	
				155	75		152	70		128	94		102	100		-	109	
			mi	✓	172		75	152		70	128		94	102		100	-	
9		ER 40		178	75		220	70		152	94		135	100		-	109	
			✓	178	75		220	70		152	94		135	100		-	109	
				195	109		210	109		140	152							
			mi	✓	195	109		210	109		140	152						
9		mi		224	109		250	109		165	152							
			✓	224	109		250	109		165	152							

# Table of Contents – Monoblock Angle Heads

Connectable in accordance with  
**BLUECOMPETENCE** » mimatic mi  
» PolyMILL » TriMILL » PolyREAM

## MAS-BT JIS 6339

Selection by  
Clearance Diameter E  
and  
Milling Depth L<sub>1</sub>

Angle Head 90°

Double  
Angle Head 90°

Angle Head 90°  
Offset Type

Angle Head 90°  
Offset Slim Type

Angle Head,  
Adjustable 0-98°



MAS-BT 40				SW			DW			ZW			ZWS			WS		
Size		Tool holder	Coolant	E Ø mm	L <sub>1</sub> mm	Page	E Ø mm	L <sub>1</sub> mm	Page	E Ø mm	L <sub>1</sub> mm	Page	E Ø mm	L <sub>1</sub> mm	Page	E Ø mm	L <sub>1</sub> mm	Page
0		ER 11											50	38				
1		ER 16	✓	91	80													
3		ER 20	✓										75	80		-	91	
		mi	✓										100	80		-	91	
5		ER 25	✓	110	80	220	125	80	221	103	80	222	82	76	223	-	96	224
		mi	✓	120	80		125	80		103	80		82	76		-	96	
				138	80		200	80		130	80		125	76		-	96	
				146	80		200	80		130	80		125	76		-	96	
7		ER 32	✓	145	80		152	80		128	100							
		mi	✓	155	80		152	80		128	100							
				172	80		220	80		150	100							
				178	80		220	80		150	100							

MAS-BT 50				SW			DW			ZW			ZWS			WS		
Size		Tool holder	Coolant	E Ø mm	L <sub>1</sub> mm	Page	E Ø mm	L <sub>1</sub> mm	Page	E Ø mm	L <sub>1</sub> mm	Page	E Ø mm	L <sub>1</sub> mm	Page	E Ø mm	L <sub>1</sub> mm	Page
0		ER 11											50	38				
5		ER 25	✓	110	75		125	70		103	79		82	76		-	96	
		mi	✓	120	75		125	70		103	79		82	76		-	96	
				138	75		200	70		133	79		125	76		-	96	
				146	75		200	70		133	79		125	76		-	96	
7		ER 32	✓	145	75	225	152	70	226	128	94	227	102	100	228	-	109	229
		mi	✓	155	75		152	70		128	94		102	100		-	109	
				172	75		220	70		152	94		135	100		-	109	
				178	75		220	70		152	94		135	100		-	109	
9		ER 40	✓	195	109		210	109		140	152							
		mi	✓	195	109		210	109		140	152							
				224	109		250	109		165	152							
				224	109		250	109		165	152							

# Table of Contents – Monoblock Angle Heads

Connectable in accordance with  
**BLUECOMPETENCE** » mimatic mi  
» PolyMILL » TriMILL » PolyREAM

## ANSI-CAT

Selection by  
Clearance Diameter E  
and  
Milling Depth L<sub>1</sub>

Angle Head 90°

Double  
Angle Head 90°

Angle Head 90°  
Offset Type

Angle Head 90°  
Offset Slim Type

Angle Head,  
Adjustable 0-98°



ANSI-CAT 40				SW			DW			ZW			ZWS			WS		
Size		Tool holder	Coolant	E Ø mm	L <sub>1</sub> mm	Page	E Ø mm	L <sub>1</sub> mm	Page	E Ø mm	L <sub>1</sub> mm	Page	E Ø mm	L <sub>1</sub> mm	Page	E Ø mm	L <sub>1</sub> mm	Page
0		ER 11											50	38				
1		ER 16		91	80													
			✓	96	80													
3		ER 20											75	80		-	91	
			✓													-	91	
5		ER 25		110	80	230	125	80	231	103	80	232	82	76	233	-	96	234
			✓	120	80		125	80		103	80		82	76		-	96	
				138	80		200	80		130	80		125	76		-	96	
			mi	✓	146		80	200		80	130		80	125		76	-	
7		ER 32		145	80		152	80		128	100							
			✓	155	80		152	80		128	100							
				172	80		220	80		150	100							
			mi	✓	178	80		220	80		150	100						

ANSI-CAT 50				SW			DW			ZW			ZWS			WS		
Size		Tool holder	Coolant	E Ø mm	L <sub>1</sub> mm	Page	E Ø mm	L <sub>1</sub> mm	Page	E Ø mm	L <sub>1</sub> mm	Page	E Ø mm	L <sub>1</sub> mm	Page	E Ø mm	L <sub>1</sub> mm	Page
0		ER 11											50	38				
5		ER 25		110	75		125	70		103	79		82	76		-	96	
			✓	120	75		125	70		103	79		82	76		-	96	
				138	75		200	70		133	79		125	76		-	96	
			mi	✓	146	75		200	70		133	79		125	76		-	96
7		ER 32		145	75	235	152	70	236	128	94	237	102	100	238	-	109	239
			✓	155	75		152	70		128	94		102	100		-	109	
				172	75		220	70		152	94		135	100		-	109	
			mi	✓	178		75	220		70	152		94	135		100	-	
9		ER 40		195	100		210	105		140	152							
			✓	195	100		210	105		140	152							
				224	100		250	105		165	152							
			mi	✓	224	100		250	105		165	152						

12

# Table of Contents – Monoblock Angle Heads

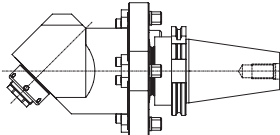
	Type	DIN	Shank	Page
<p><b>SW</b></p> <p><b>Angle Head 90°</b> Gear Ratio <math>i = 1:1</math> Coolant supply: without / external / internal</p> 	SW	DIN 69871	SK 40	200
		DIN 69893 A	SK 50	205
			HKS 63	210
			HSK 100	215
		MAS-BT JIS 6339	BT 40	220
	BT 50	225		
	ANSI-CAT	CAT 40	230	
		CAT 50	235	
<p><b>DW</b></p> <p><b>Double Angle Head 90°</b> Gear Ratio <math>i = 1:1</math> Coolant supply: without / external</p> 	DW	DIN 69871	SK 40	201
		DIN 69893 A	SK 50	206
			HKS 63	211
			HSK 100	216
		MAS-BT JIS 6339	BT 40	221
	BT 50	226		
	ANSI-CAT	CAT 40	231	
		CAT 50	236	
<p><b>ZW</b></p> <p><b>Angle Head 90° Offset type</b> Gear Ratio <math>i = 1:1</math> Coolant supply: without / external / internal</p> 	ZW	DIN 69871	SK 40	202
		DIN 69893 A	SK 50	207
			HKS 63	212
			HSK 100	217
		MAS-BT JIS 6339	BT 40	222
	BT 50	227		
	ANSI-CAT	CAT 40	232	
		CAT 50	237	
<p><b>ZWS</b></p> <p><b>Angle Head 90° Offset Slim type</b> Gear Ratio <math>i = 1:1</math> Coolant supply: without / external</p> 	ZWS	DIN 69871	SK 40	203
		DIN 69893 A	SK 50	208
			HKS 63	213
			HSK 100	218
		MAS-BT JIS 6339	BT 40	223
	BT 50	228		
	ANSI-CAT	CAT 40	233	
		CAT 50	238	
<p><b>WS</b></p> <p><b>Angle Head, adjustable 0-98°</b> Gear Ratio <math>i = 1:1</math> or <math>1:2,25</math> Coolant supply: internal</p> 	WS	DIN 69871	SK 40	204
		DIN 69893 A	SK 50	209
			HKS 63	214
			HSK 100	219
		MAS-BT JIS 6339	BT 40	224
	BT 50	229		
	ANSI-CAT	CAT 40	234	
		CAT 50	239	
<p><b>Angle Head with fixed angle</b></p> 	FW	Available on request.		

## Angle Drilling Heads and Cutter Heads

mimatic® has been a reliable partner in project planning and the supply of precision tools worldwide for many years in the field of chip removing production.

In addition to toolholding systems and cutting tools, the company also provides driven tools for both CNC lathes and CNC machining centers to solve customer-specific problems with chip removal.

The company has provided many special purpose solutions for **angle heads and cutter heads** since its foundation in 1974. In doing so, mimatic has always placed special emphasis on **maximum precision, power transmission, operating safety and quality.**

We ensure close cooperation with our customers worldwide, providing advice on all machining problems – even on-site. We realize and implement our solutions on the basis of our **comprehensive standard program or by means of customer-specific special developments and designs.**

Our new standard program of **angle head tools** provides our customers with the means for complete, integrated machining. It is now no longer necessary to repeatedly relocate tools, which means a considerable reduction in production costs, rationalization and the increase in flexibility over the entire production process.

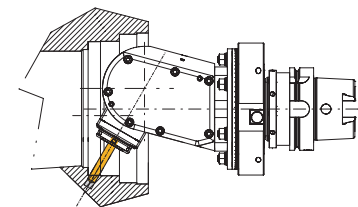
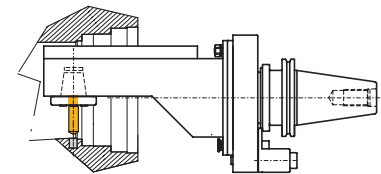
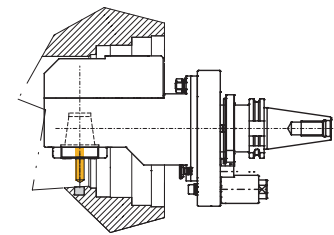
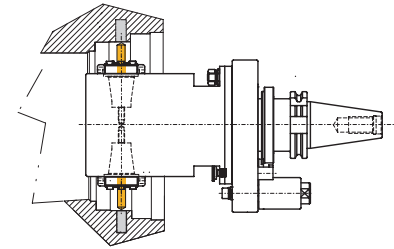
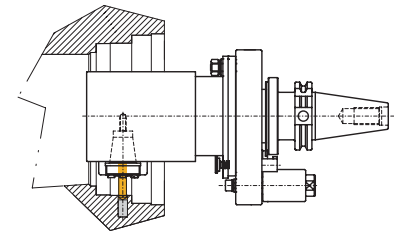

## Features of the mimatic® Angle Heads

mimatic® angle heads increase the efficiency of your production. They allow you to work on inaccessible areas within housings or bores.

The angle heads can be used in all popular machine concepts, such as CNC machining centers with automatic or manual tool change and special-purpose machines with fixed insert. They are optimally designed for the respective machining task.

We use ground bevel gears with helical profile as well as hardened and ground spur gears to ensure smooth operation and high power transmission.

### Versions

- mimatic® angle heads are available in all European and international shank variants:
  - **SK per DIN 69871, ANSI-CAT, MAS-BT and**
  - **HSK to DIN 69893 – Form A**
 other standards and sizes are also available on request
- With **standard torque support according to ISO 9524** (to be adapted by the customer)
- Available on request with 3-point support adapted to the machine and stop block
- Tool changing manual or automatic
- For drilling, reaming, countersinking, threading and milling
- Allows the machining of sections of the workpiece which are otherwise inaccessible (e.g. internal machining)
- A large number of special, customized designs for complex machining problems
- Single, dual or multi-spindle variants are available
- Fixed angles can be made, as opposed to using Adjustables or standard 90 Degree Heads
- Available on request with internal coolant supply via the spindle (70 bar)
- High torque transmission
- Available as standard with **collet chuck model „ER“ according to DIN 6499** or with our modular **„mi“ quick-change tool system** – compatible with all popular tool fittings (collet chucks, Weldon, Whistle-Notch, hydraulic chucks, shrink fit chucks, combi milling arbors, etc.)
- with mimatic® „SYNTAX“ thread quick-change chuck

### mimatic „mi“

#### Modular quick-change tool system



### mimatic „SYNTAX“

#### Tapping quick-change holder





## Design of the Angle Heads

- **High-precision spindle bearing, P4 quality** with medium bias voltage (lifelong lubrication of bearing), suitable for high speeds (up to 15,000 rpm)
- **Stabilized spindle bearing** (inside tool holding spindle, i.e. point of load incidence within the housing, therefore low leverage)
- **Bevel gear sets with helical profile**
- **Permanent lubrication** of the gear with heavy-duty lubricant (low-maintenance)
- Possibilities for **coolant supply**:
  - **without**
  - **external** via coolant pipe
  - **internal** via the tool holding spindle („i.K.“ – package with packing sleeves, hardened upthrust washer, friction-optimized seals and various O-rings)
- Use of **friction-optimized** seals with PTFE sealing lips, for higher speeds, high temperature resistance
- **Output orientation is fully adjustable** (0–360° via the 6 setscrews on the adjusting ring)
- **Angle head can be rotated through 360° and is infinitely variable** – additional 6 x 15° indexations for adjustable angle units
- High **speeds up to 15,000 rpm** and **high torques up to 150 Nm**
- The **torque support is designed according to ISO 9524 as standard**. This can be adapted by the customer
- Different **standard stop block** versions are available. If necessary, these are to be adapted and fitted to the machine tool by the customer.

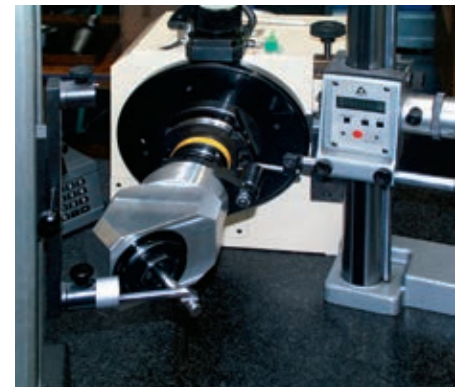

## Performance Values

The torques  $M_{max}$  specified in the tables below refer to shock-free processing (e.g. threaded cutting). For processes involving major shock loads (e.g. milling or multi-edge knocking), a value reduction of up to 50 % and more needs to be taken into account. The values  $n_{max}$  and  $P_{max}$  rendered are guideline values for short-time operation.

The permissible relative operating duration depends

- on the version of the spindle unit (with or without gear)
- on the presence of a cooling system and the type of cooling (external or internal through the tool spindle)
- on the processing torque

At a charge of about 60 % of the maximum values the working life calculated amounts to approx. 2.000 hours. Spindle units with gears produce more noise at higher speeds!

### Operating Instructions

**Initial Start-up:** To ensure long tool life it is important to properly "run-in" the tools. This procedure serves to reduce the internal friction in the driven unit and to evenly distribute the grease in the precision bearings.

- **Max. RPM in the first operation hour should not exceed 70 % of the maximum permissible RPM.**
- **Never run the tool above the maximum permissible torque rate and/or maximum permissible RPM (see also the drawing of the unit).**

**Tools with internal coolant through the spindle (i.C.):** To avoid premature wear and damage to the seal system we recommend to filter the coolant to 40  $\mu\text{m}$  minimum.

Filter grades of 40  $\mu\text{m}$  worked in operation with very good results. The maximum permissible coolant pressure can be taken from the technical data of the driven toolholder.

Driven Toolholders with internal coolant through the spindle (i.C.) should **never run without coolant**. The coolant should flow through the tool, before the tool drive is switched on. Running in dry condition damages the internal seals.

**Service interval:** The tool life of the driven toolholder depends strongly on the application. Wear parts such as bearings and seals should be exchanged. We recommend to send the tools at least once annually to our service center for cleaning and regreasing. Tools with internal coolant through the spindle should be serviced every 6 months.

### Optimum relative cycle times (guideline values)

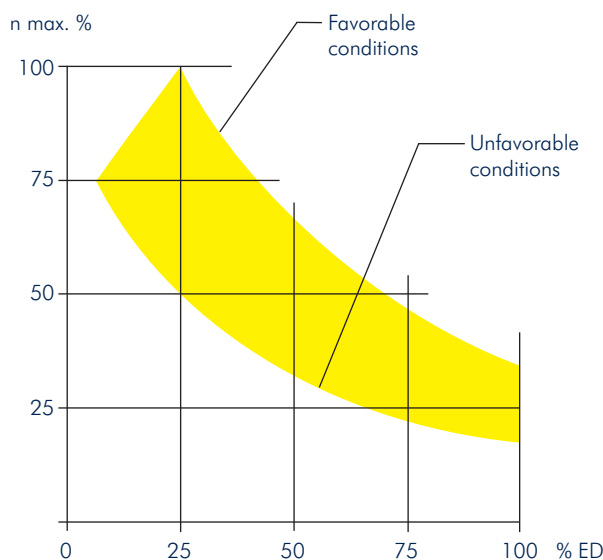

### Determination of the maximum permissible cycle times per minute $ED_{max}$

The maximum permissible cycle times per minute may not be under any circumstances exceeded.

CT max: maximum permissible cycle times in percent per minute (%/min.)

## Features of the Standard Angle Heads

- **Extremely precise Bearing Technology**
- **High Concentricity**
- **High Rigidity**

mimatic® angle heads are designed in such a way that they increase the quality of your workpieces and the service life of your tools.

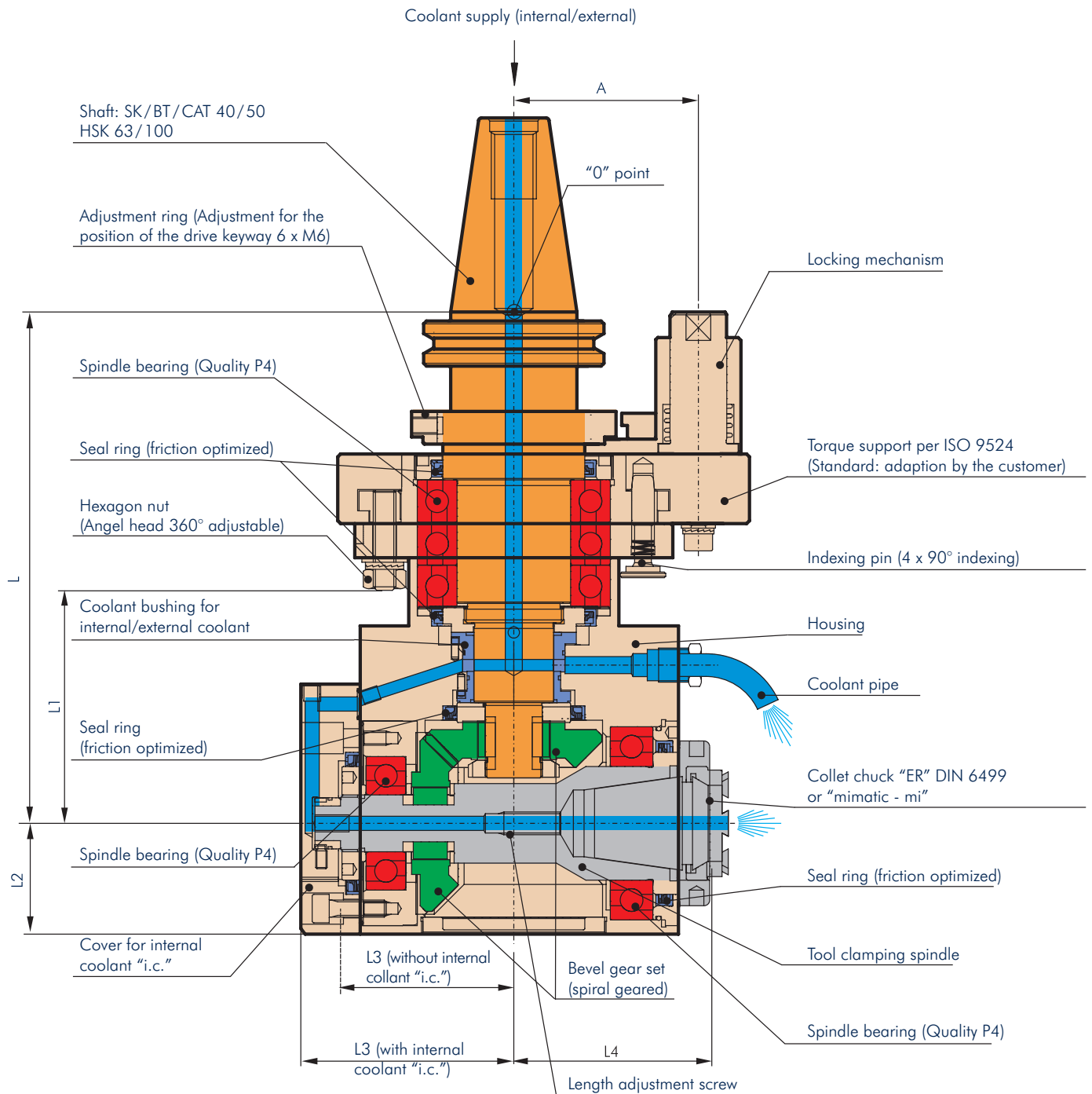

**SK 40**

**SW**

## Angle Head 90°

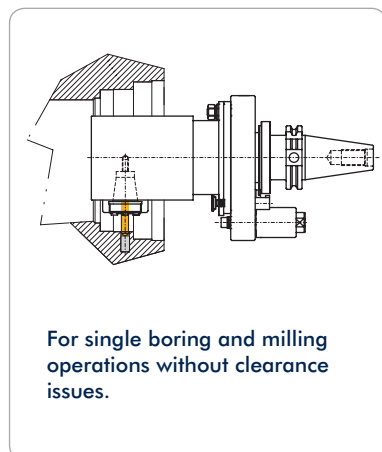

For single boring and milling operations without clearance issues.



**Attention!**  
Reversal of rotation direction

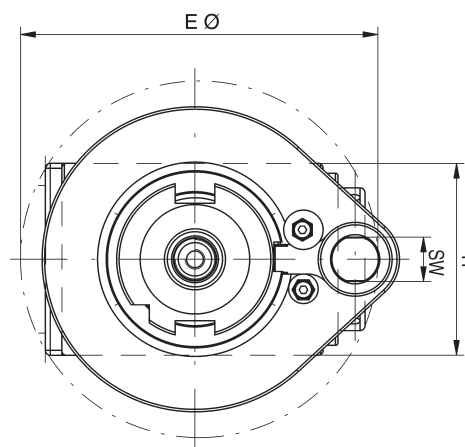
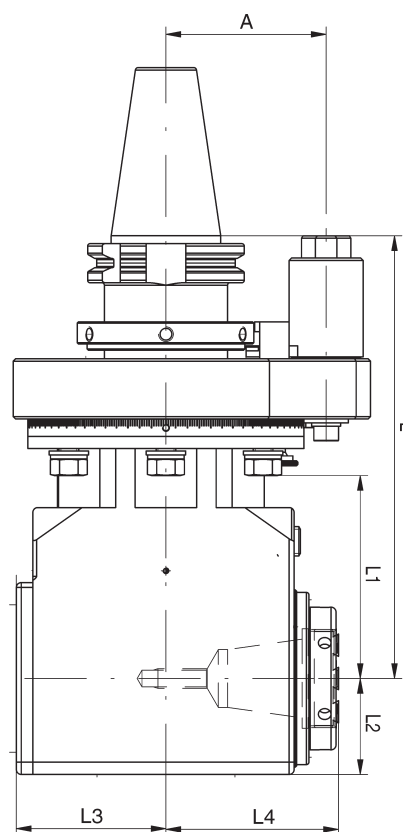
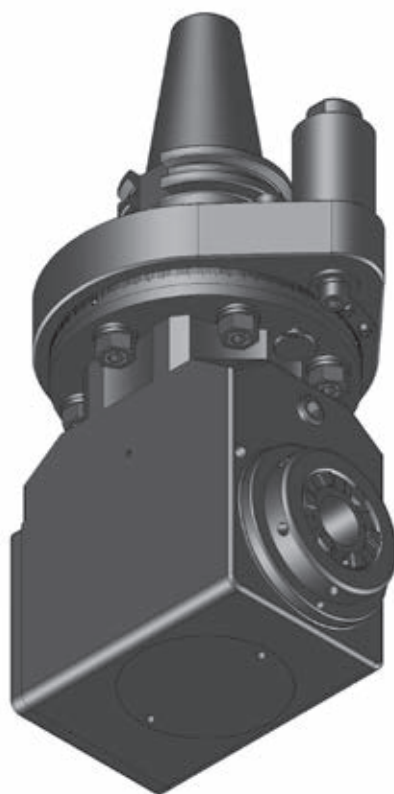

Size	Torque max.	Rev. max. (r.p.m.)	Gear Ratio	L mm	L1 mm	L2 mm	H mm	A mm	kg	SW
1	12 Nm	10.000	i = 1:1	180	80	22	44	65	6,0	18
5	30 Nm	8.000	i = 1:1	180	80	34	68	65	6,5	18
7	70 Nm	6.500	i = 1:1	180	80	39	78	65	8,0	18

Size	Toolholder	Clearance dia. E mm		L3 mm		L4 mm		Order No.		
		without coolant	with coolant	without coolant	with coolant	without coolant	with coolant	without coolant	external coolant	internal coolant
1	ER 16	91	96	29,0	44	45,0	50	105485	105679	105695
5	ER 25	110	120	41,5	52	57,5	63	105493	162767	105507
5	mi 40	138	146	41,5	52	72,0	72	105490	162799	105513
7	ER 32	145	155	61,0	75	70,0	75	135486	105516	105539
7	mi 50	172	178	61,0	75	83,0	83	135453	162790	162791

**SK 40**

**DW**

## Double Angle Head 90°

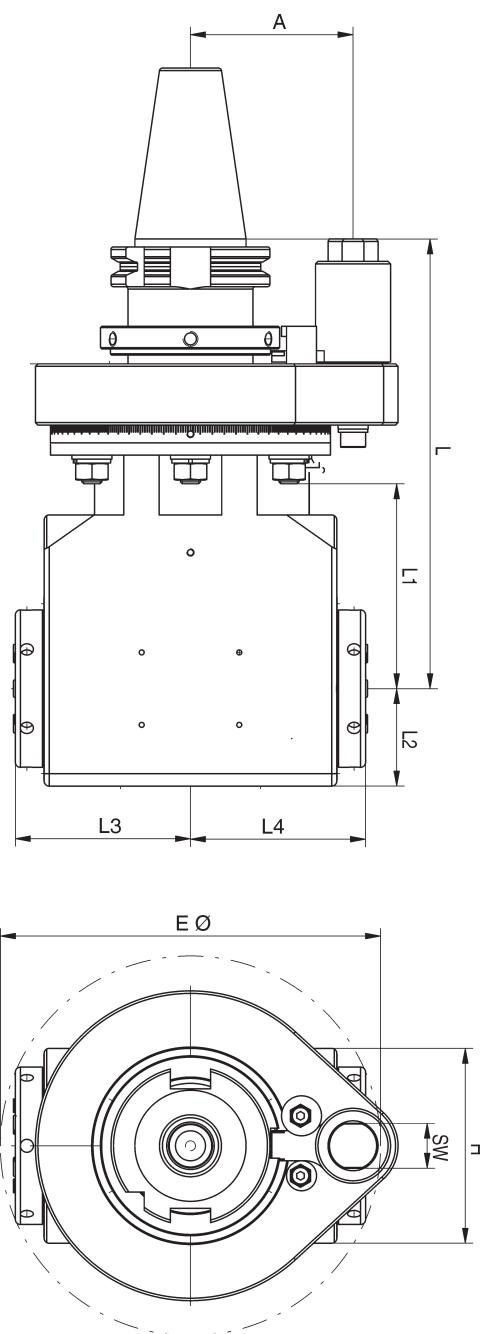
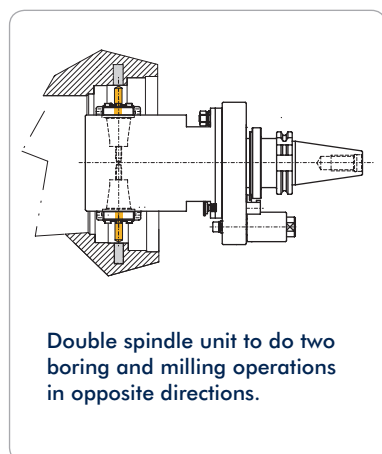

Size	Torque max.	Rev. max. (r.p.m.)	Gear Ratio	L mm	L1 mm	L2 mm	H mm	A mm	kg	SW
5	30 Nm	8.000	i = 1:1	180	80	39	78	65	7,5	18
7	70 Nm	6.500	i = 1:1	180	80	39	78	65	8,5	18

Size	Toolholder	Clearance dia. E mm		L3 mm		L4 mm		Order No.		
		without coolant	with coolant	without coolant	with coolant	without coolant	with coolant	without coolant	external coolant	internal coolant
5	2 x ER 25	125	125	62,0	62,0	62,0	62,0	135710	168317	
5	2 x mi 32	200	200	76,5	76,5	76,5	76,5	173507	162838	
7	2 x ER 32	152	152	71,2	71,2	71,2	71,2	135733	166009	
7	2 x mi 40	220	220	88,0	88,0	88,0	88,0	105775	174400	

12

**SK 40**

**ZW**

## Angle Head 90°, Offset Type

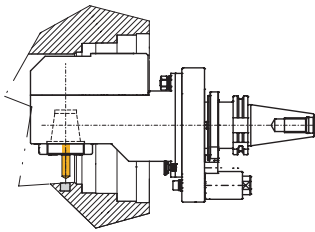

Rear offset unit with increased usable tool length and internal coolant is an option.

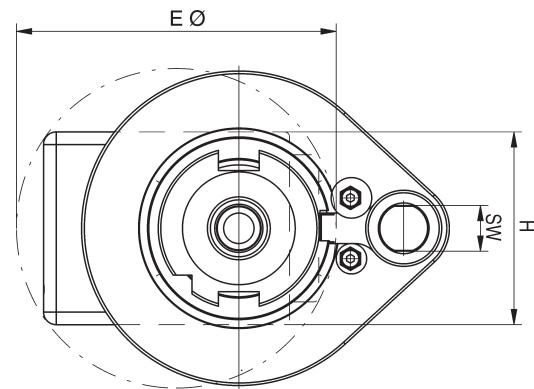
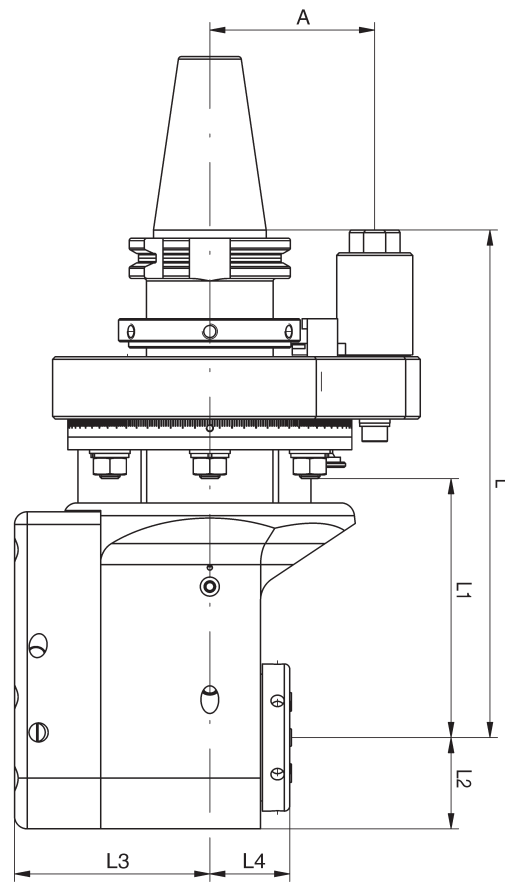
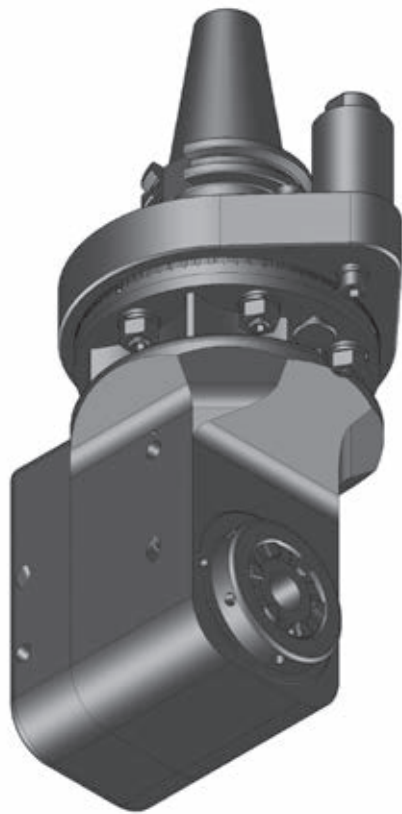

Size	Torque max.	Rev. max. (r.p.m.)	Gear Ratio	L mm	L1 mm	L2 mm	H mm	A mm	kg	SW
5	30 Nm	8.000	i = 1:1	180	80	28,5	57	65	6,5	18
7	70 Nm	6.000	i = 1:1	198	100	38,0	76	65	8,5	18

Size	Toolholder	Clearance dia. E mm		L3 mm		L4 mm		Order No.		
		without coolant	with coolant	without coolant	with coolant	without coolant	with coolant	without coolant	external coolant	internal coolant
5	ER 25	103	103	57,0	57,0	35,8	41,6	135389	162855	168670
5	mi 40	130	130	57,0	57,0	50,3	50,3	105439	162879	162880
7	ER 32	128	128	77,5	77,5	32,2	38,0	105440	162868	105478
7	mi 50	150	150	77,5	77,5	55,0	55,0	105429	162894	162895

**SK 40**

**ZWS**

## Angle Head 90°, Offset Slim Type

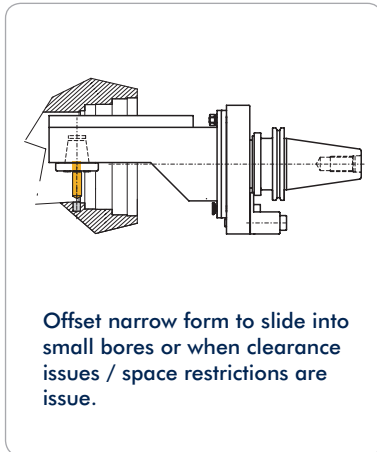

Offset narrow form to slide into small bores or when clearance issues / space restrictions are issue.



**Attention!**  
Reversal of rotation direction

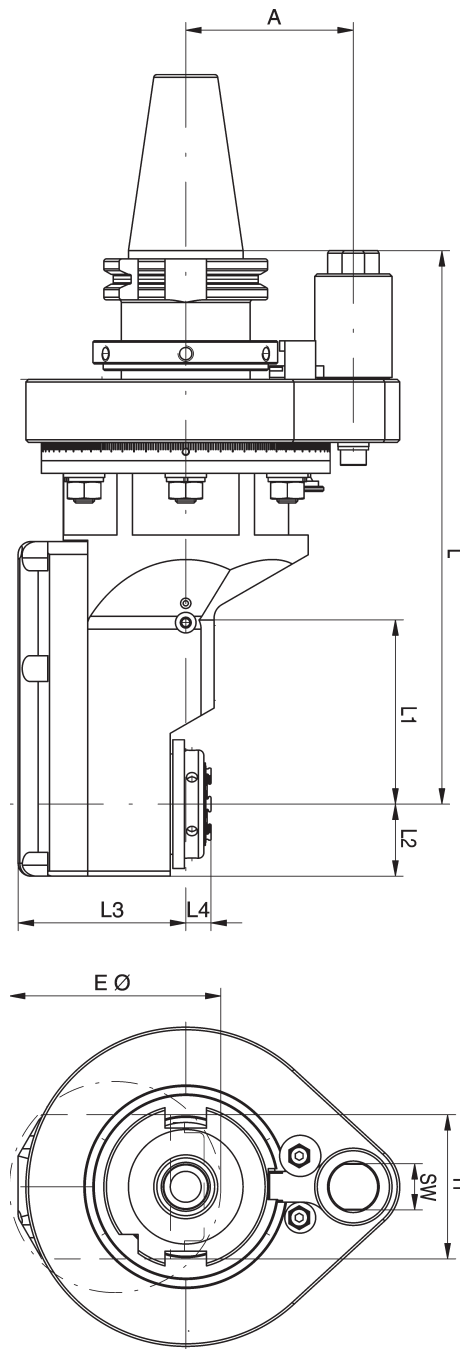
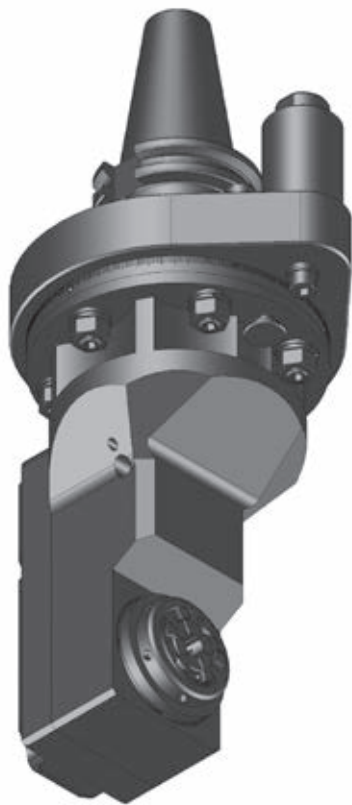

Size	Torque max.	Rev. max. (r.p.m.)	Gear Ratio	L mm	L1 mm	L2 mm	H mm	A mm	kg	SW
0	6 Nm	12.000	i = 1:1,67	213	38	20	36	65	7,0	18
3	15 Nm	10.000	i = 1:1	225	80	24	48	65	6,0	18
5	30 Nm	8.000	i = 1:1	215	76	28	56	65	6,5	18

Size	Toolholder	Clearance dia. E mm		L3 mm		L4 mm		Order No.		
		without coolant	with coolant	without coolant	with coolant	without coolant	with coolant	without coolant	external coolant	internal coolant
0	ER 11	50		49,0		-8,0		105631		
3	ER 20	75		54,5		11,2		105665		
3	mi 32	100		54,5		26,0		173535		
5	ER 25	82	82	65,0	65	10,0	10,0	135615	162922	
5	mi 40	125	125	65,0	65	23,5	23,5	135609	162934	

**SK 40**

**WS**

Connectable in accordance with **BLUECOMPETENCE** » mimatic mi » PolyMILL » TriMILL » PolyREAM

## Angle Head, Adjustable 0-98°

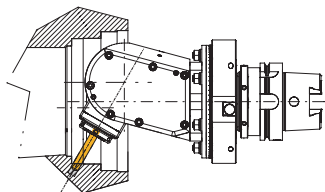

Adjustable angle unit to do boring and milling applications at any angle.

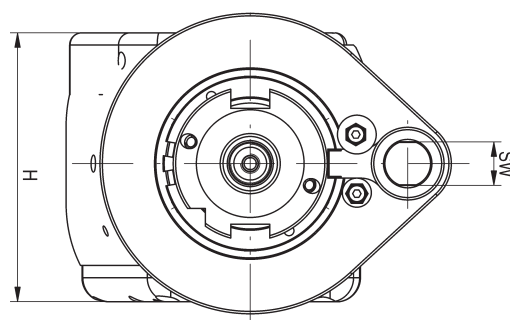
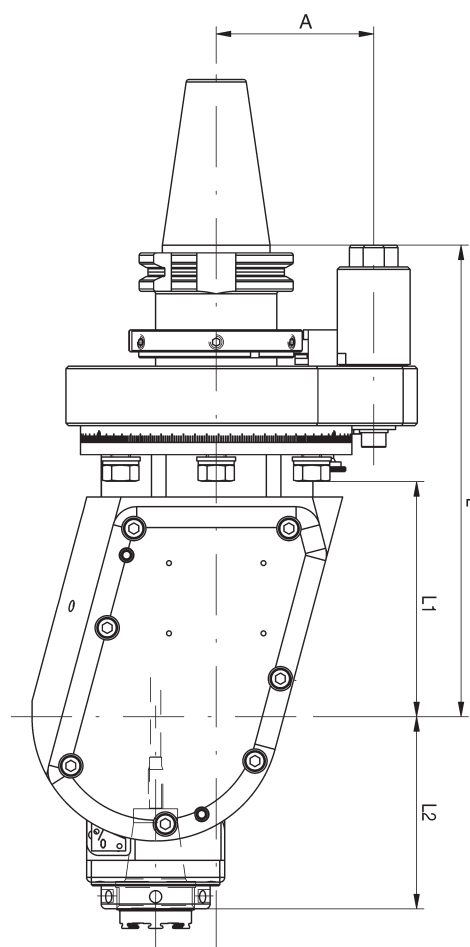
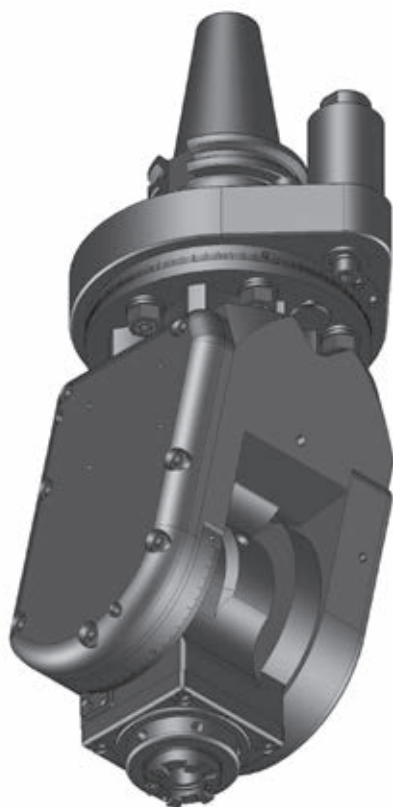

Size	Torque max.	Rev. max. (r.p.m.)	Gear Ratio	L mm	L1 mm	H mm	A mm	kg	SW
3	15 Nm	8.000 / 15.000	i = 1:1 / 1:2,25	189	91	96	65	8,0	18
5	30 Nm	7.000 / 13.500	i = 1:1 / 1:2,25	195	96	111	65	9,6	18

Size	Toolholder	L2 mm	L4 mm	Order No. (i=1:1)		Order No. (i=1:2,25)	
				without coolant	internal coolant	without coolant	internal coolant
3	ER 20	75,0	20	162793	105825	156560	105823
3	mi 32	82,9	20	156561	105832	156562	156563
5	ER 25	84,0	25	174413	105833	156580	105826
5	mi 40	97,0	25	162952	169975	162953	162954



**SK 50**

**SW**

## Angle Head 90°

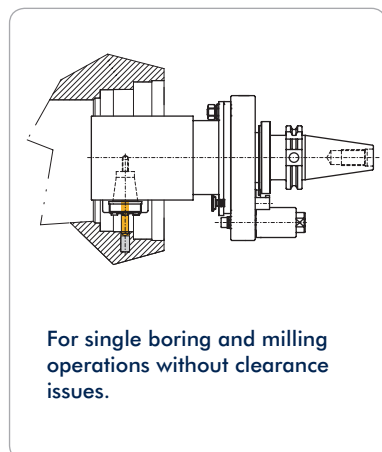

For single boring and milling operations without clearance issues.



**Attention!**  
Reversal of rotation direction

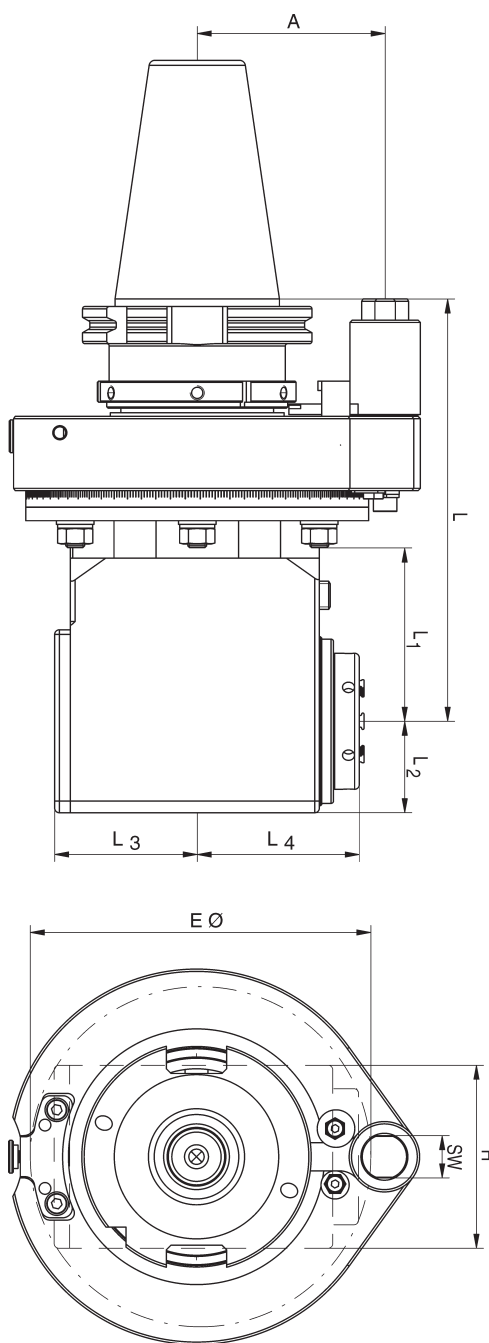
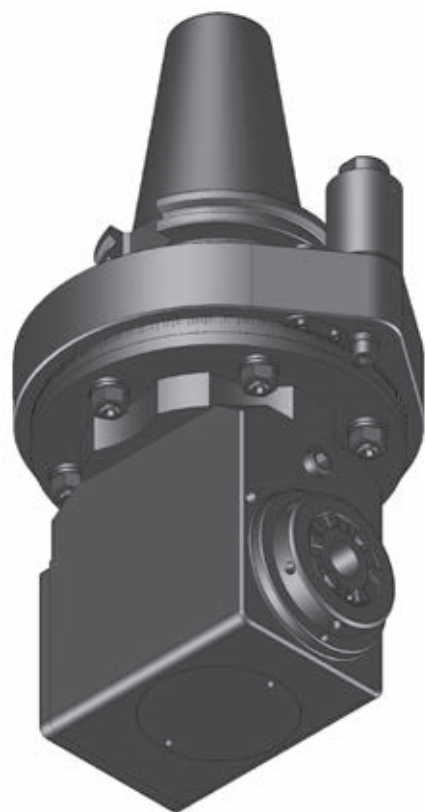

Size	Torque max.	Rev. max. (r.p.m.)	Gear Ratio	L mm	L1 mm	L2 mm	H mm	A mm	kg	SW
5	30 Nm	8.000	i = 1:1	180	75	34	68	80	10,5	18
7	70 Nm	6.500	i = 1:1	180	75	39	78	80	12,0	18
9	150 Nm	5.000	i = 1:1	215	105	52	104	80	18,0	18

Size	Toolholder	Clearance dia. E mm		L3 mm		L4 mm		Order No.		
		without coolant	with coolant	without coolant	with coolant	without coolant	with coolant	without coolant	external coolant	internal coolant
5	ER 25	110	120	41,5	52	57,5	63,0	135458	135446	135447
5	mi 40	138	146	41,5	52	72,0	72,0	167870	162806	105500
7	ER 32	145	155	61,0	75	70,0	75,0	135476	162778	166720
7	mi 50	172	178	61,0	75	83,0	83,0	105519	162795	105522
9	ER 40	195	195	81,0	81	92,0	96,0	105551	162780	169469
9	mi 63	224	224	81,0	81	111,5	111,5	173083	162784	166543

**SK 50**

**DW**

Connectable in accordance with **BLUECOMPETENCE** » mimatic mi » PolyMILL » TriMILL » PolyREAM

## Double Angle Head 90°

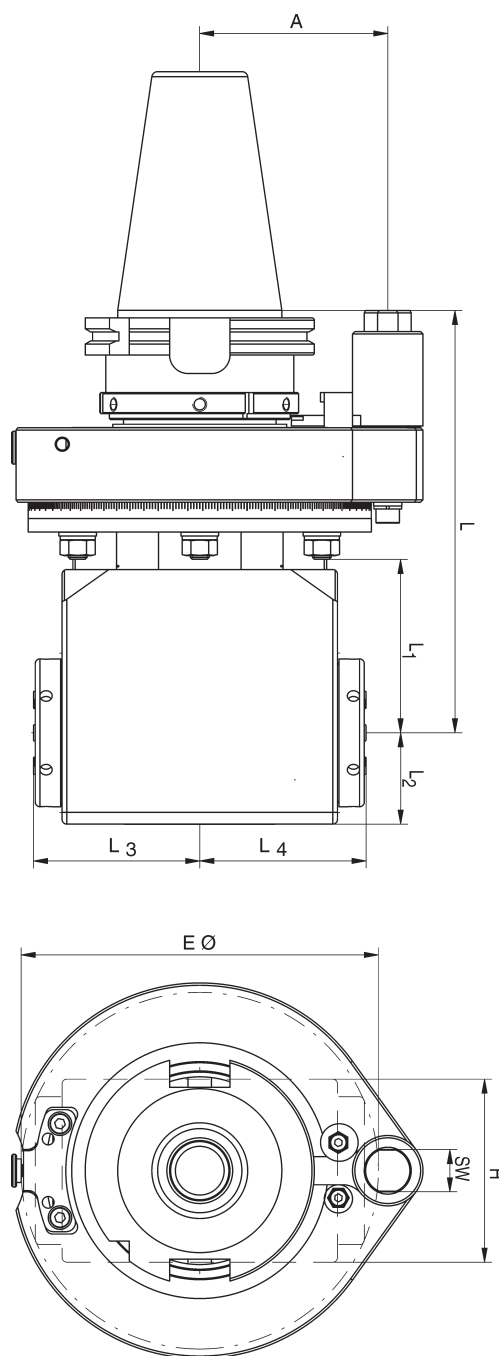
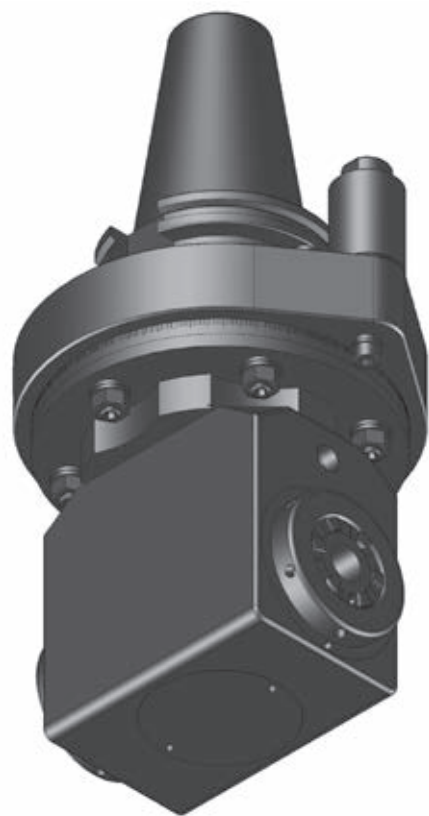
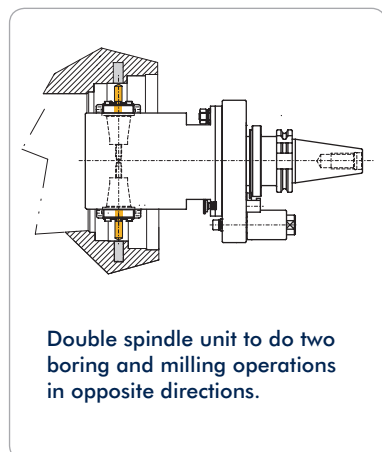

Size	Torque max.	Rev. max. (r.p.m.)	Gear Ratio	L mm	L1 mm	L2 mm	H mm	A mm	kg	SW
5	30 Nm	8.000	i = 1:1	180	70	34	68	80	11,5	18
7	70 Nm	6.500	i = 1:1	180	70	39	78	80	13,5	18
9	150 Nm	4.000	i = 1:1	215	109	58	108	80	20,0	18

Size	Toolholder	Clearance dia. E mm		L3 mm		L4 mm		Order No.		
		without coolant	with coolant	without coolant	with coolant	without coolant	with coolant	without coolant	external coolant	internal coolant
5	2 x ER 25	125	125	62,0	62,0	62,0	62,0	135678	162825	
5	2 x mi 32	200	200	76,5	76,5	76,5	76,5	173511	162842	
7	2 x ER 32	152	152	71,2	71,2	71,2	71,2	135734	167532	
7	2 x mi 40	220	220	88,0	88,0	88,0	88,0	167238	105776	
9	2 x ER 40	210	210	103,0	103,0	103,0	103,0	105784	162834	
9	2 x mi 50	250	250	116,0	116,0	116,0	116,0	167654	162851	

**SK 50**

**ZW**

## Angle Head 90°, Offset Type

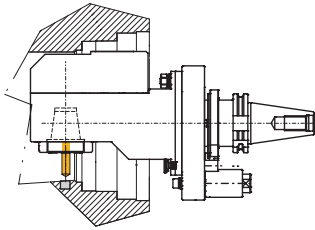

Rear offset unit with increased usable tool length and internal coolant is an option.

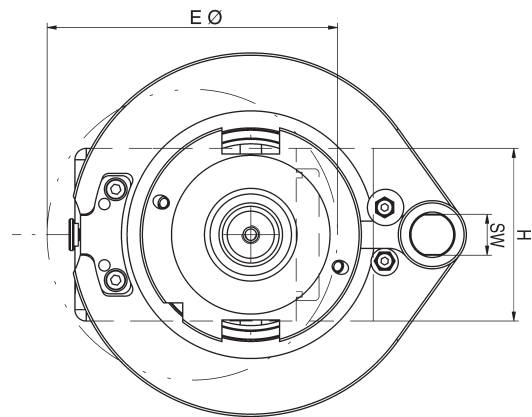
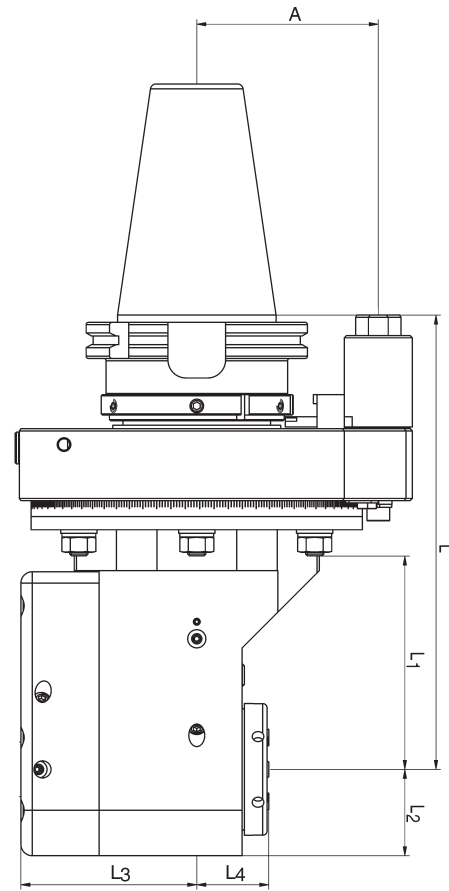
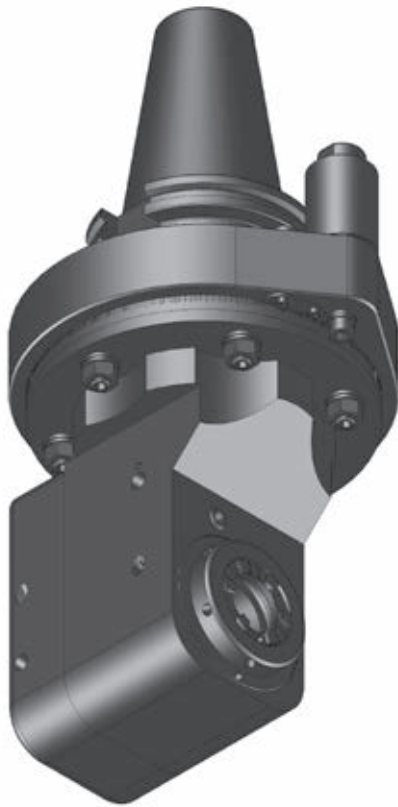

Size	Torque max.	Rev. max. (r.p.m.)	Gear Ratio	L mm	L1 mm	L2 mm	H mm	A mm	kg	SW
5	30 Nm	8.000	i = 1:1	185	79	28,5	57	80	11,5	18
7	70 Nm	6.000	i = 1:1	200	94	38,0	76	80	14,0	18
9	150 Nm	5.000	i = 1:1	260	152	52,0	104	80	19,0	18

Size	Toolholder	Clearance dia. E mm		L3 mm		L4 mm		Order No.		
		without coolant	with coolant	without coolant	with coolant	without coolant	with coolant	without coolant	external coolant	internal coolant
5	ER 25	103	103	58,0	58,0	35,8	41,6	105416	162861	162862
5	mi 40	133	133	58,0	58,0	50,3	50,3	173523	162886	162887
7	ER 32	128	128	77,5	77,5	32,2	38,0	105430	162871	105479
7	mi 50	152	152	77,5	77,5	55,0	55,0	169908	162900	105475
9	ER 40	140	140	89,0	89,0	31,0	34,8	105482	162874	162876
9	mi 63	165	165	89,0	89,0	48,3	48,3	105468	162904	162905

12

**SK 50** **ZWS**

## Angle Head 90°, Offset Slim Type

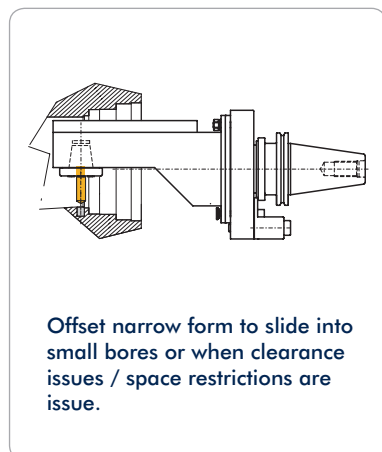

Offset narrow form to slide into small bores or when clearance issues / space restrictions are issue.



**Attention!**  
Reversal of rotation direction

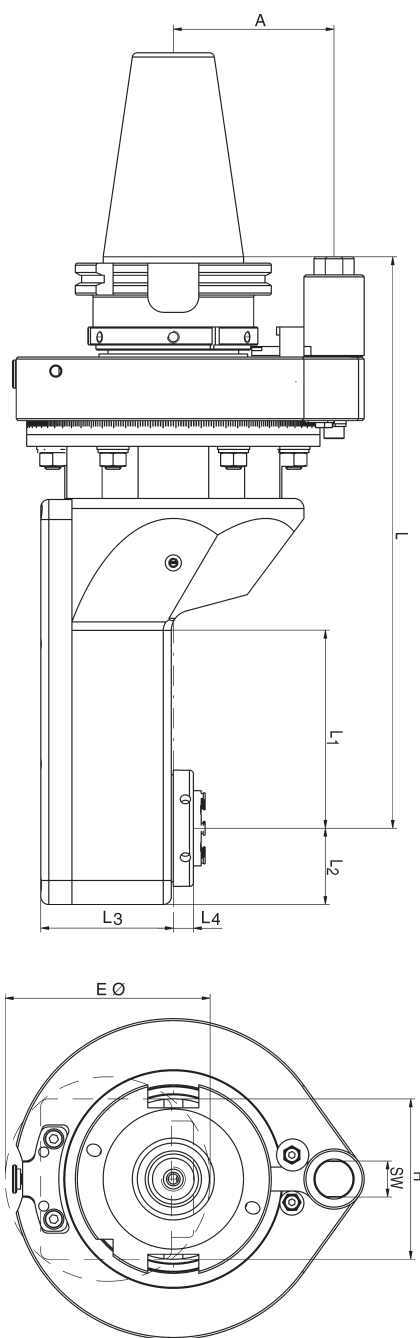
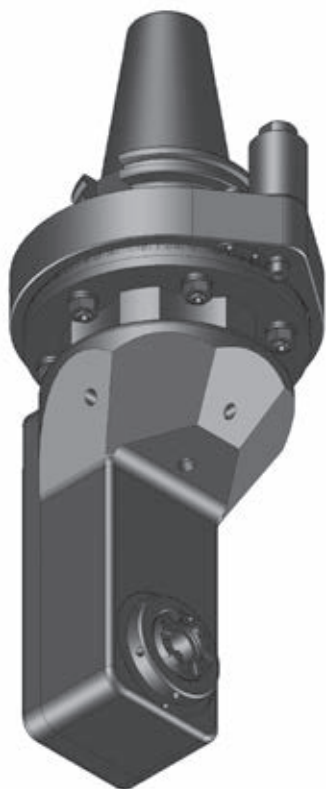

Size	Torque max.	Rev. max. (r.p.m.)	Gear Ratio	L mm	L1 mm	L2 mm	H mm	A mm	kg	SW
0	6 Nm	12.000	i = 1:1,67	227,5	38	20	36	80	11,0	18
5	30 Nm	8.000	i = 1:1	215,0	76	28	56	80	12,5	18
7	70 Nm	6.000	i = 1:1	285,0	100	38	80	80	13,5	18

Size	Toolholder	Clearance dia. E mm		L3 mm		L4 mm		Order No.		
		without coolant	with coolant	without coolant	with coolant	without coolant	with coolant	without coolant	external coolant	internal coolant
0	ER 11	50		49		-8,0		105650		
5	ER 25	82	82	65	65	10,0	10,0	105682	162926	
5	mi 40	125	125	65	65	23,5	23,5	173539	162938	
7	ER 32	102	102	66	66	13,0	13,0	135643	105684	
7	mi 50	135	135	66	66	29,0	29,0	167741	162942	

**SK 50**

**WS**

## Angle Head, Adjustable 0-98°

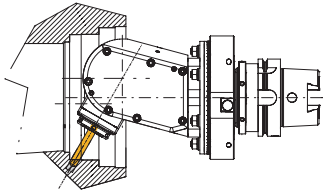

Adjustable angle unit to do boring and milling applications at any angle.

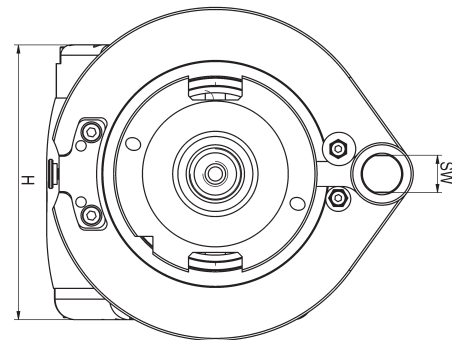
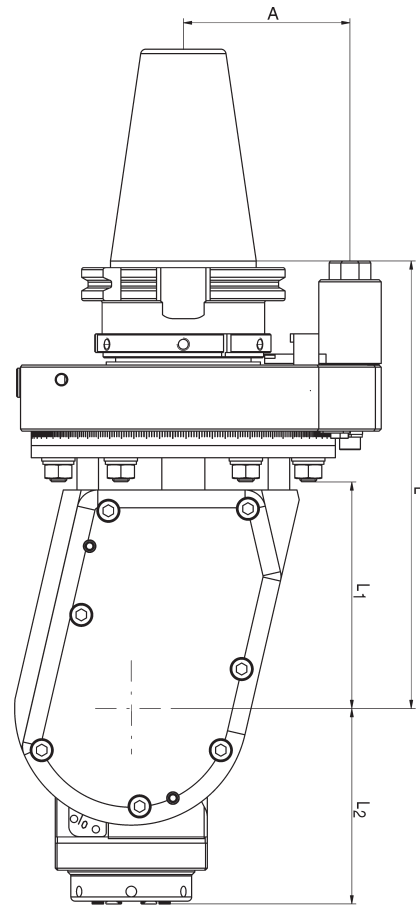
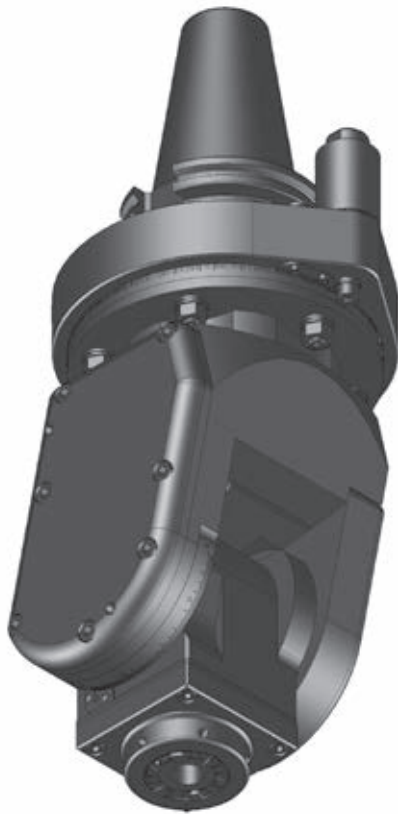

Size	Torque max.	Rev. max. (r.p.m.)	Gear Ratio	L mm	L1 mm	H mm	A mm	kg	SW
5	30 Nm	7.000 / 13.500	i = 1:1 / 1:2,25	195	96	111	80	14,0	18
7	70 Nm	6.000	i = 1:1	215	108	132	80	16,0	18

Size	Toolholder	L2 mm	L4 mm	Order No. (i=1:1)		Order No. (i=1:2,25)	
				without coolant	internal coolant	without coolant	internal coolant
5	ER 25	84	25	162965	135816	135823	162966
5	mi 40	97	25	162967	167021	162968	162969
7	ER 32	95	25	162982	105864		
7	mi 50	108	25	162989	166981		

12

**HSK 63**

**SW**

## Angle Head 90°

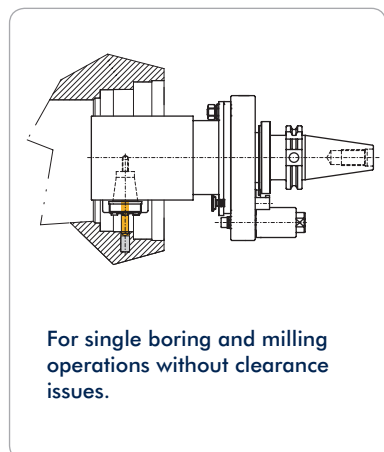

For single boring and milling operations without clearance issues.



**Attention!**  
Reversal of rotation direction

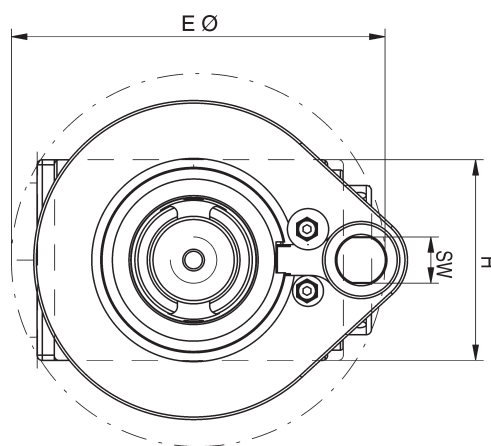
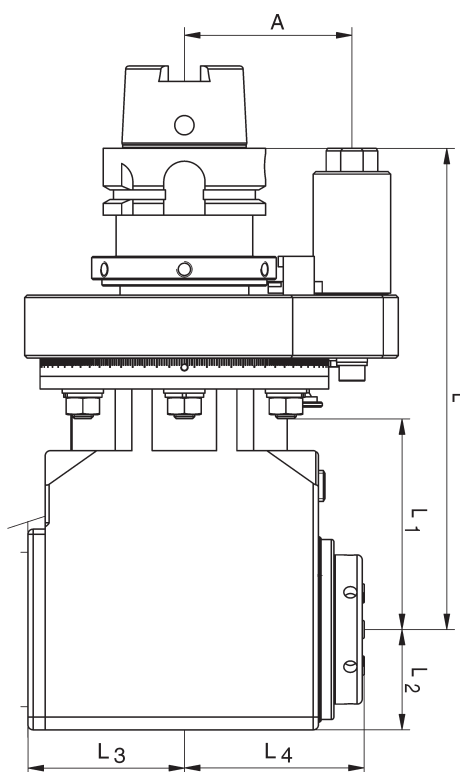
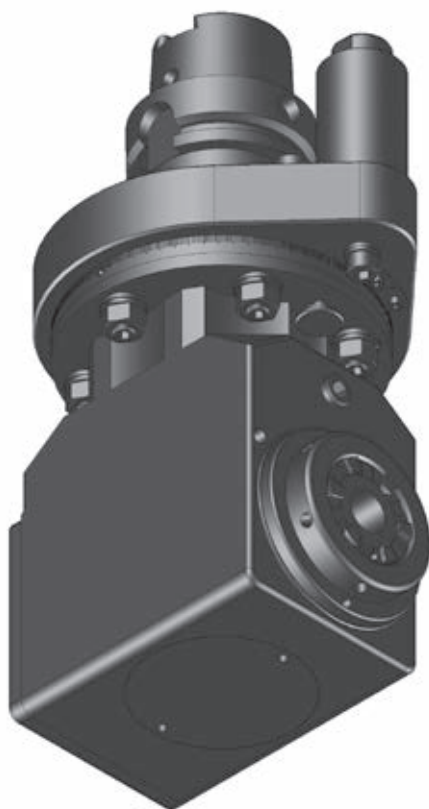

Size	Torque max.	Rev. max. (r.p.m.)	Gear Ratio	L mm	L1 mm	L2 mm	H mm	A mm	kg	SW
1	12 Nm	10.000	i = 1:1	187	80	22	44	65	6,0	18
5	30 Nm	8.000	i = 1:1	187	80	34	68	65	6,5	18
7	70 Nm	6.500	i = 1:1	187	80	39	78	65	8,0	18

Size	Toolholder	Clearance dia. E mm		L3 mm		L4 mm		Order No.		
		without coolant	with coolant	without coolant	with coolant	without coolant	with coolant	without coolant	external coolant	internal coolant
1	ER 16	91	96	29,0	44	45,0	50	135456	162792	135452
5	ER 25	110	120	41,5	52	57,5	63	135433	105491	105501
5	mi 40	138	146	41,5	52	72,0	72	169846	162804	162805
7	ER 32	145	155	61,0	75	70,0	75	135489	105528	105533
7	mi 50	172	178	61,0	75	83,0	83	105504	162794	105540

**HSK 63 DW**

## Double Angle Head 90°

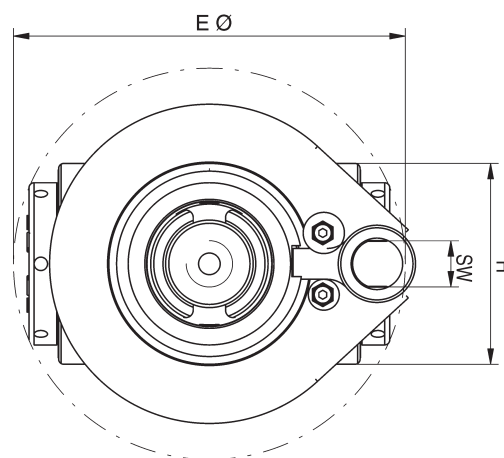
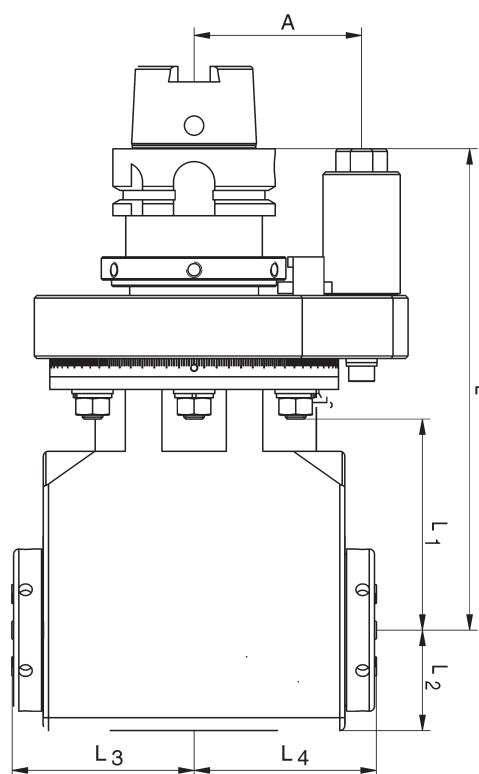
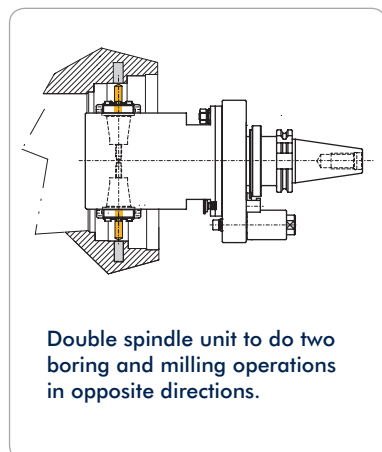

Size	Torque max.	Rev. max. (r.p.m.)	Gear Ratio	L mm	L1 mm	L2 mm	H mm	A mm	kg	SW
5	30 Nm	8.000	i = 1:1	187	80	39	78	65	7,5	18
7	70 Nm	6.500	i = 1:1	187	80	39	78	65	8,5	18

Size	Toolholder	Clearance dia. E mm		L3 mm		L4 mm		Order No.		
		without coolant	with coolant	without coolant	with coolant	without coolant	with coolant	without coolant	external coolant	internal coolant
5	2 x ER 25	125	125	62,0	62,0	62,0	62,0	135706	162824	
5	2 x mi 32	200	200	76,5	76,5	76,5	76,5	173510	162841	
7	2 x ER 32	152	152	71,2	71,2	71,2	71,2	135747	162830	
7	2 x mi 40	220	220	88,0	88,0	88,0	88,0	170454	176644	

**HSK 63**

**ZW**

## Angle Head 90°, Offset Type

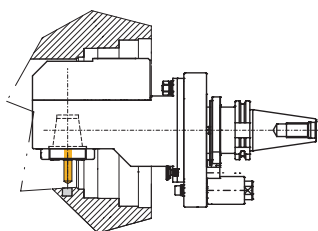

Rear offset unit with increased usable tool length and internal coolant is an option.

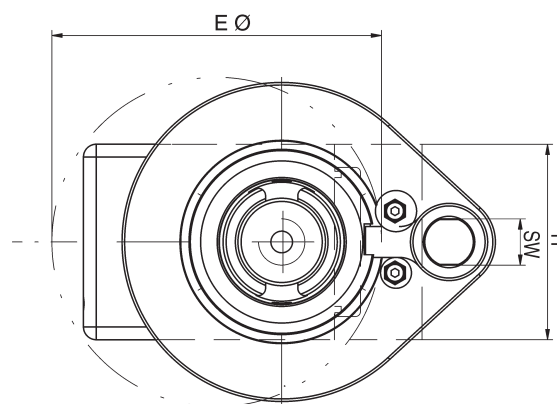
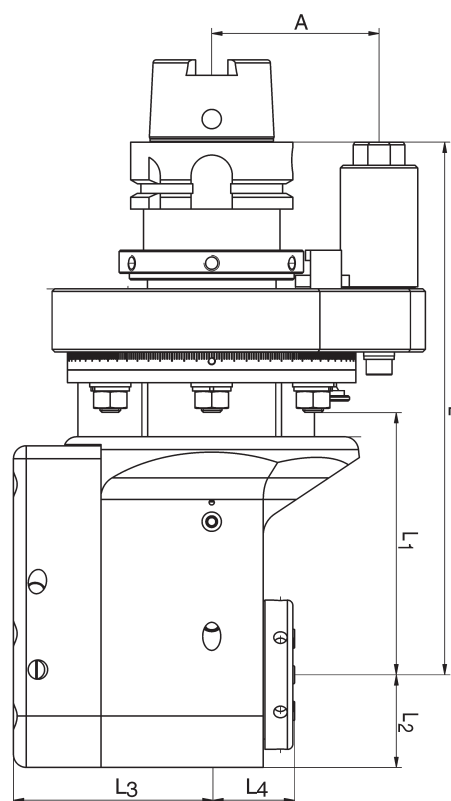
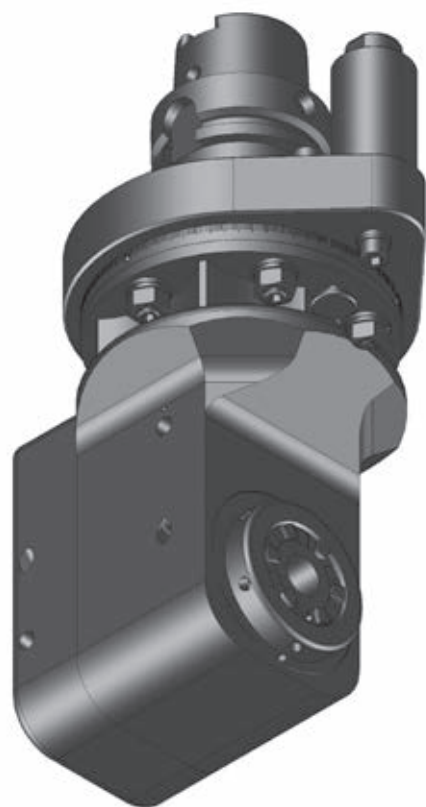

Size	Torque max.	Rev. max. (r.p.m.)	Gear Ratio	L mm	L1 mm	L2 mm	H mm	A mm	kg	SW
5	30 Nm	8.000	i = 1:1	187	80	28,5	57	65	6,5	18
7	70 Nm	6.000	i = 1:1	205	100	38,0	76	65	8,5	18

Size	Toolholder	Clearance dia. E mm		L3 mm		L4 mm		Order No.		
		without coolant	with coolant	without coolant	with coolant	without coolant	with coolant	without coolant	external coolant	internal coolant
5	ER 25	103	103	57,0	57,0	35,8	41,6	135405	162860	167996
5	mi 40	130	130	57,0	57,0	50,3	50,3	105459	162884	162885
7	ER 32	128	128	77,5	77,5	34,0	38,0	135416	174283	135398
7	mi 50	150	150	77,5	77,5	55,0	55,0	173528	162899	167022



**HSK 63**

**ZWS**

## Angle Head 90°, Offset Slim Type

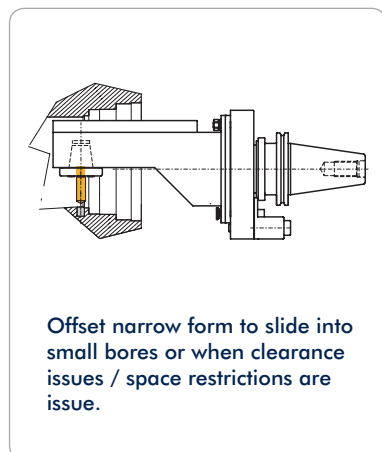

Offset narrow form to slide into small bores or when clearance issues / space restrictions are issue.



**Attention!**  
Reversal of rotation direction

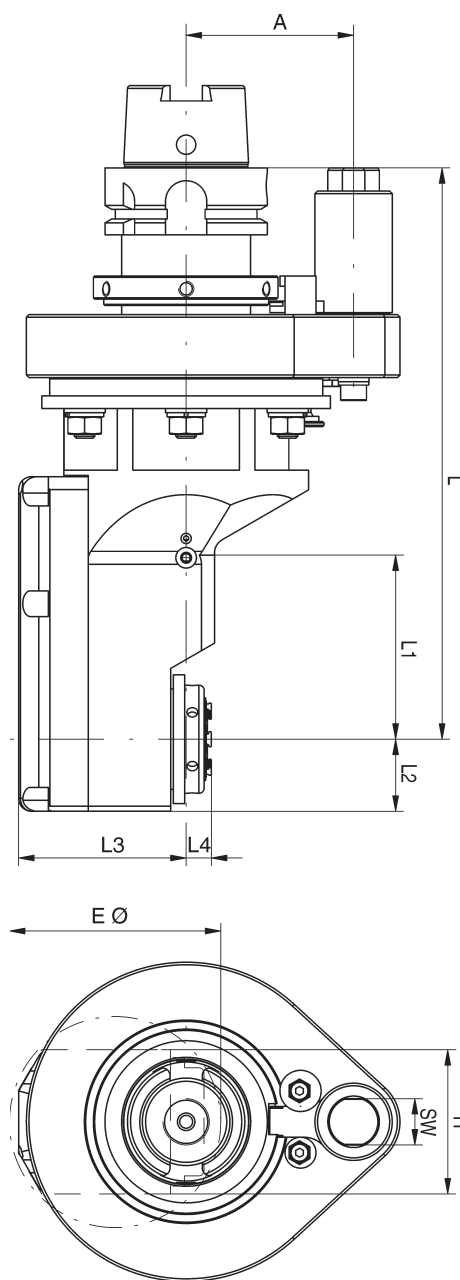
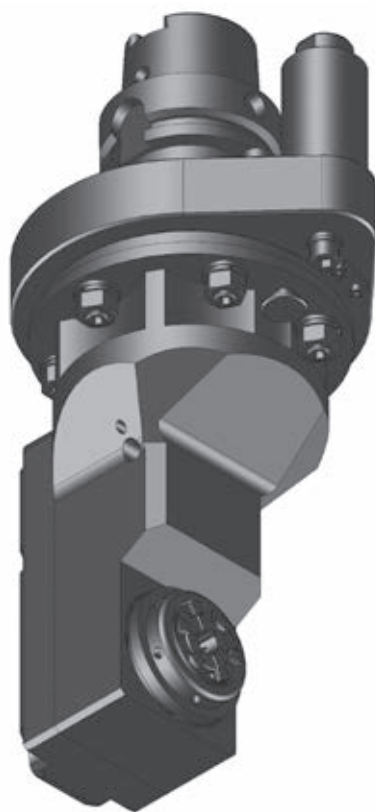

Size	Torque max.	Rev. max. (r.p.m.)	Gear Ratio	L mm	L1 mm	L2 mm	H mm	A mm	kg	SW
0	6 Nm	12.000	i = 1:1,67	220	38	20	36	65	7,0	18
3	15 Nm	10.000	i = 1:1	232	80	24	48	65	6,0	18
5	30 Nm	8.000	i = 1:1	222	76	28	56	65	6,5	18

Size	Toolholder	Clearance dia. E mm		L3 mm		L4 mm		Order No.		
		without coolant	with coolant	without coolant	with coolant	without coolant	with coolant	without coolant	external coolant	internal coolant
0	ER 11	50		49,0		-8,0		105670		
3	ER 20	75		54,5		11,2		135633		
3	mi 32	100		54,5		26,0		105671		
5	ER 25	82	82	65,0	65	10,0	10,0	105674	162925	
5	mi 40	125	125	65,0	65	23,5	23,5	105686	162937	

**HSK 63**

**WS**

## Angle Head, Adjustable 0-98°

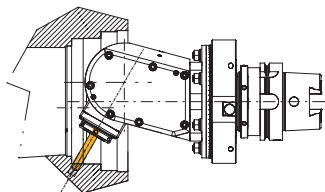

Adjustable angle unit to do boring and milling applications at any angle.

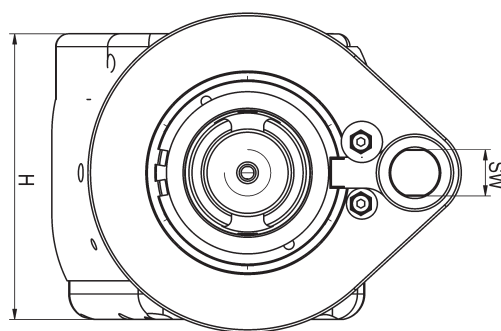
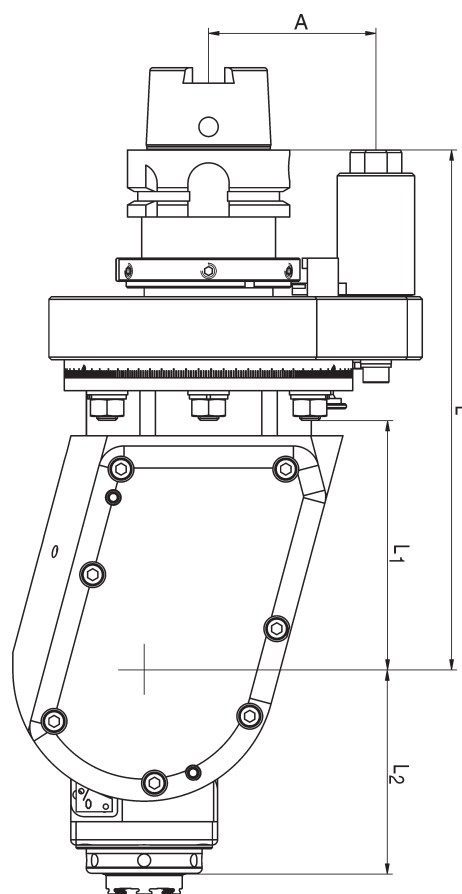
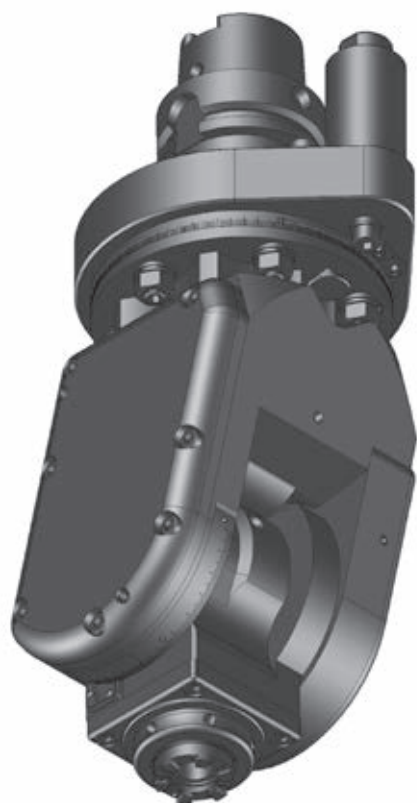

Size	Torque max.	Rev. max. (r.p.m.)	Gear Ratio	L mm	L1 mm	H mm	A mm	kg	SW
3	15 Nm	8.000 / 15.000	i = 1:1 / 1:2,25	196	91	96	65	8,0	18
5	30 Nm	7.000 / 13.500	i = 1:1 / 1:2,25	202	96	111	65	9,6	18

Size	Toolholder	L2 mm	L4 mm	Order No. (i=1:1)		Order No. (i=1:2,25)	
				without coolant	internal coolant	without coolant	internal coolant
3	ER 20	75,0	20	162945	105840	156558	156559
3	mi 32	82,9	20	156577	169142	156578	156579
5	ER 25	84,0	25	162961	135824	162962	135832
5	mi 40	97,0	25	162963	105853	162964	105858

**HSK 100 SW**

## Angle Head 90°

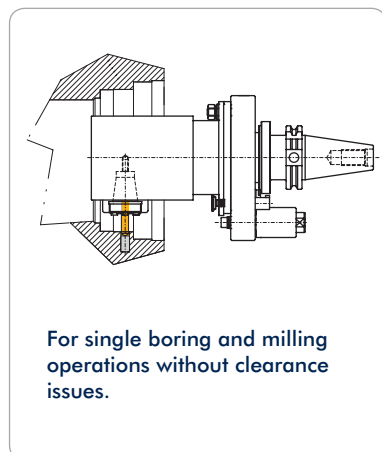

For single boring and milling operations without clearance issues.



**Attention!**  
Reversal of rotation direction

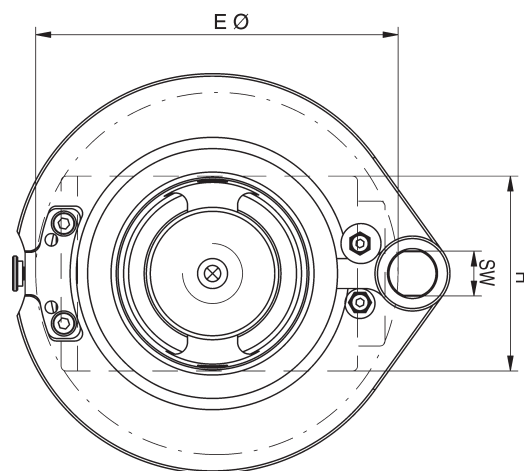
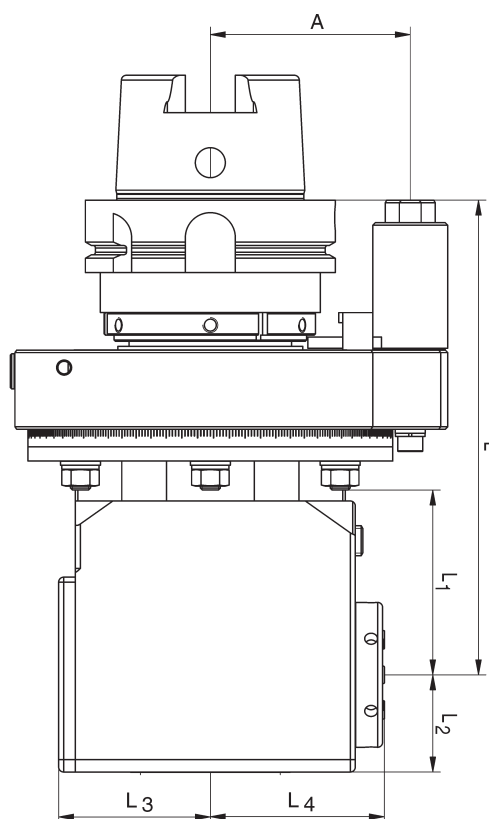
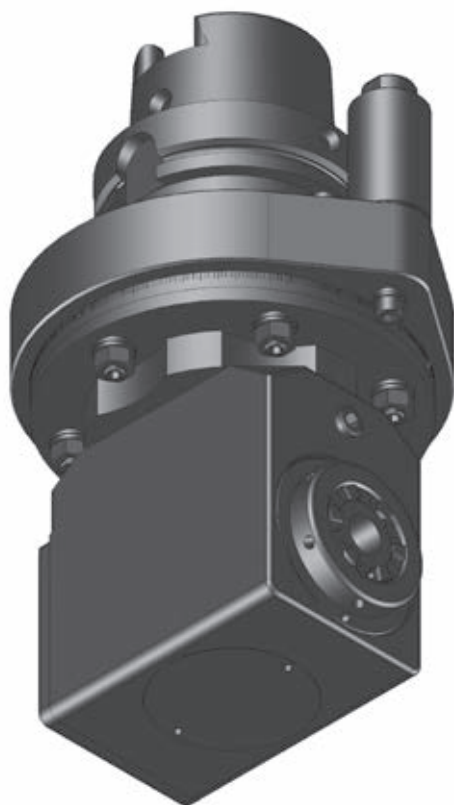

Size	Torque max.	Rev. max. (r.p.m.)	Gear Ratio	L mm	L1 mm	L2 mm	H mm	A mm	kg	SW
5	30 Nm	8.000	i = 1:1	190	75	34	68	80	10,5	18
7	70 Nm	6.500	i = 1:1	190	75	39	78	80	12,0	18
9	150 Nm	5.000	i = 1:1	225	109	52	104	80	18,0	18

Size	Toolholder	Clearance dia. E mm		L3 mm		L4 mm		Order No.		
		without coolant	with coolant	without coolant	with coolant	without coolant	with coolant	without coolant	external coolant	internal coolant
5	ER 25	110	120	41,5	52	57,5	63,0	105499	162774	135462
5	mi 40	138	146	41,5	52	72,0	72,0	172644	162811	162812
7	ER 32	145	155	61,0	75	70,0	75,0	105515	169103	105506
7	mi 50	172	178	61,0	75	83,0	83,0	167699	176169	162798
9	ER 40	195	195	81,0	81	92,0	96,0	105557	169104	105544
9	mi 63	224	224	81,0	81	111,5	111,5	173506	162788	162789

**HSK 100**

**DW**

## Double Angle Head 90°

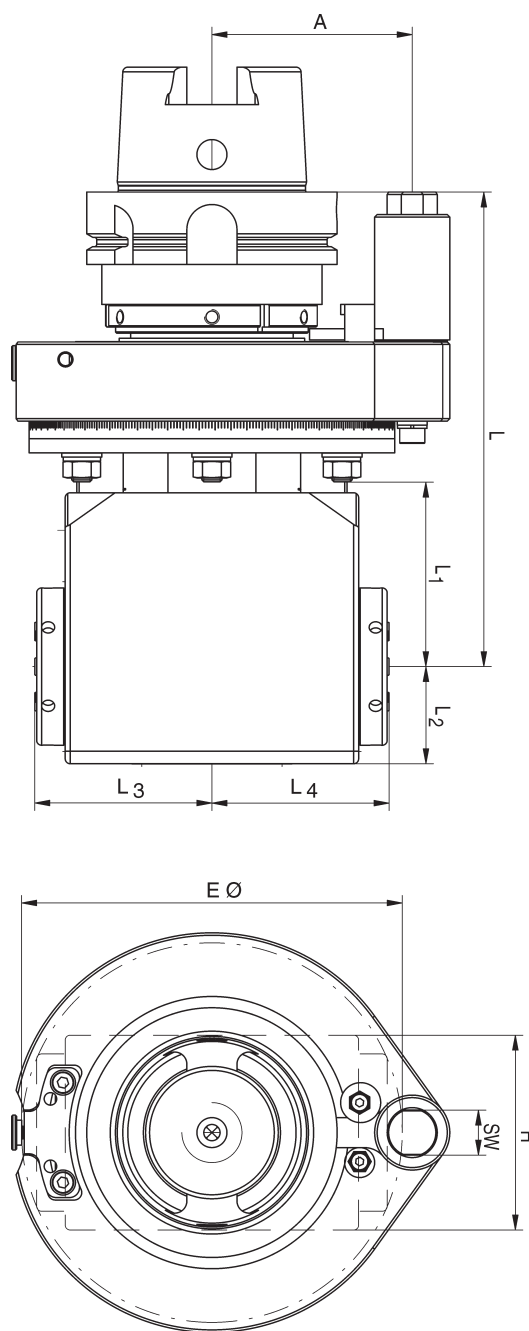
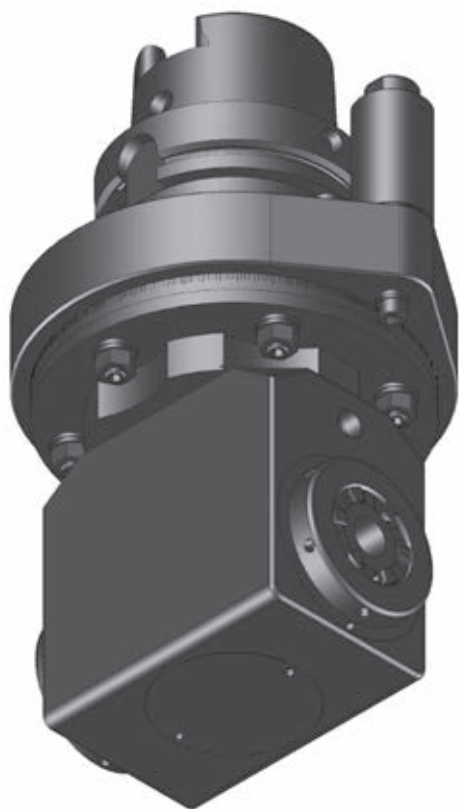
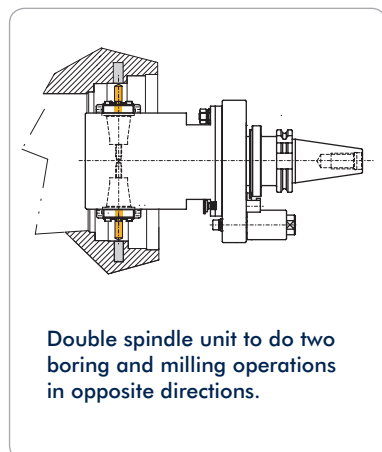

Size	Torque max.	Rev. max. (r.p.m.)	Gear Ratio	L mm	L1 mm	L2 mm	H mm	A mm	kg	SW
5	30 Nm	8.000	i = 1:1	190	70	34	68	80	11,5	18
7	70 Nm	6.500	i = 1:1	190	70	39	78	80	13,5	18
9	150 Nm	4.000	i = 1:1	225	109	58	108	80	20,0	18

Size	Toolholder	Clearance dia. E mm		L3 mm		L4 mm		Order No.		
		without coolant	with coolant	without coolant	with coolant	without coolant	with coolant	without coolant	external coolant	internal coolant
5	2 x ER 25	125	125	62,0	62,0	62,0	62,0	135711	162827	
5	2 x mi 32	200	200	76,5	76,5	76,5	76,5	173514	162845	
7	2 x ER 32	152	152	71,2	71,2	71,2	71,2	135749	162833	
7	2 x mi 40	220	220	88,0	88,0	88,0	88,0	167700	162850	
9	2 x ER 40	210	210	103,0	103,0	103,0	103,0	105790	162837	
9	2 x mi 50	250	250	116,0	116,0	116,0	116,0	167705	162854	

**HSK 100** **ZW**

## Angle Head 90°, Offset Type

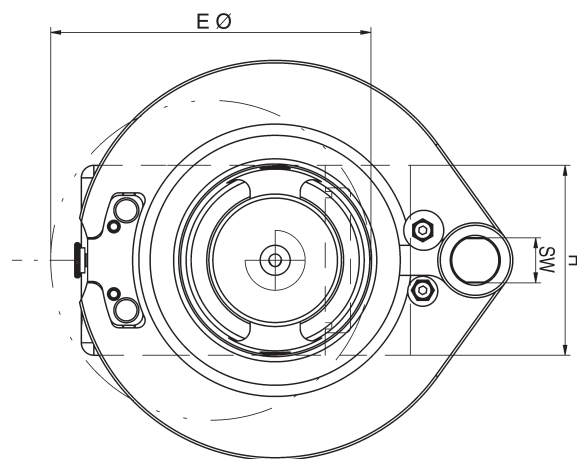
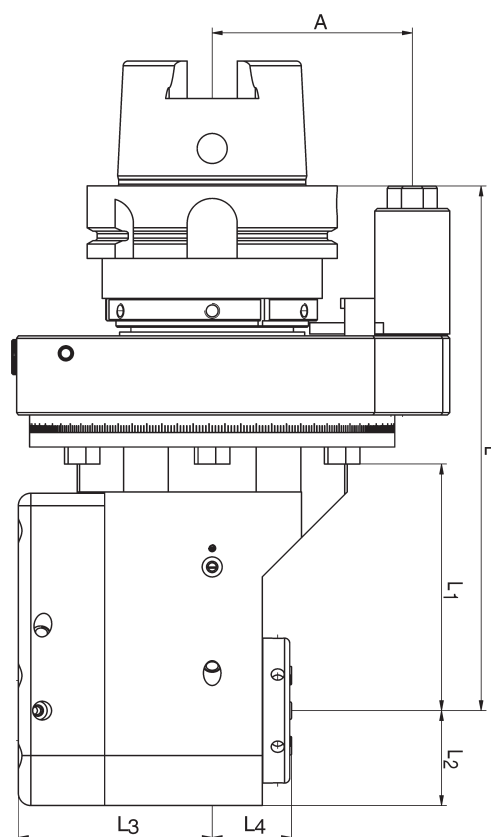
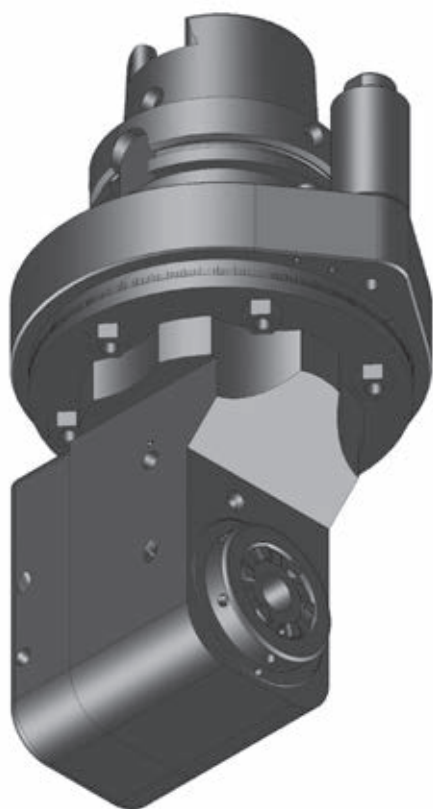
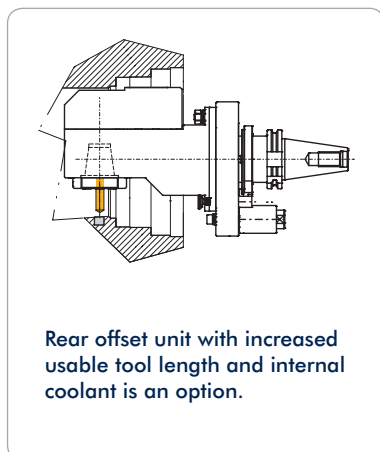

12

Size	Torque max.	Rev. max. (r.p.m.)	Gear Ratio	L mm	L1 mm	L2 mm	H mm	A mm	kg	SW
5	30 Nm	8.000	i = 1:1	195	79	28,5	57	80	11,5	18
7	70 Nm	6.500	i = 1:1	210	94	38,0	76	80	14,0	18
9	150 Nm	5.000	i = 1:1	270	152	52,0	104	80	19,0	18

Size	Toolholder	Clearance dia. E mm		L3 mm		L4 mm		Order No.		
		without coolant	with coolant	without coolant	with coolant	without coolant	with coolant	without coolant	external coolant	internal coolant
5	ER 25	103	103	58,0	58,0	35,8	41,6	105466	162867	168564
5	mi 40	133	133	58,0	58,0	50,3	50,3	173522	162892	162893
7	ER 32	128	128	77,5	77,5	32,2	38,0	105431	162873	166868
7	mi 50	152	152	77,5	77,5	55,0	55,0	173529	162903	105469
9	ER 40	140	140	89,0	89,0	31,0	34,8	135375	105471	135399
9	mi 63	165	165	89,0	89,0	48,3	48,3	173534	162910	168369

**HSK 100** **ZWS**

## Angle Head 90°, Offset Slim Type

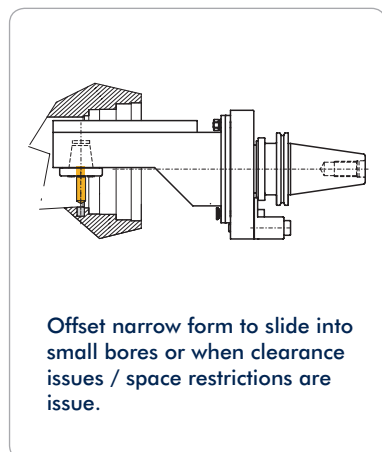

Offset narrow form to slide into small bores or when clearance issues / space restrictions are issue.



**Attention!**  
Reversal of rotation direction

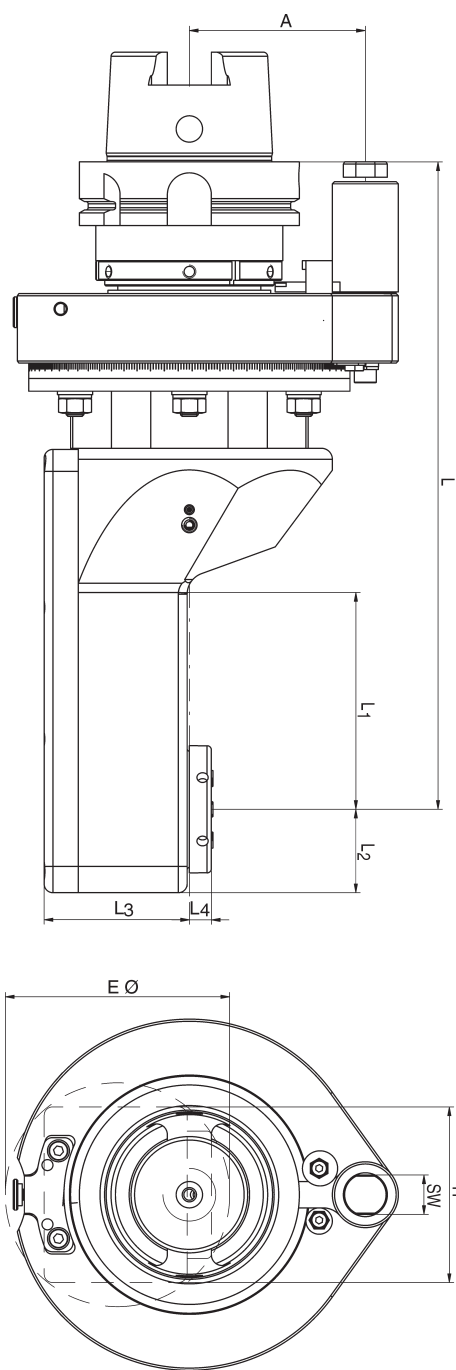
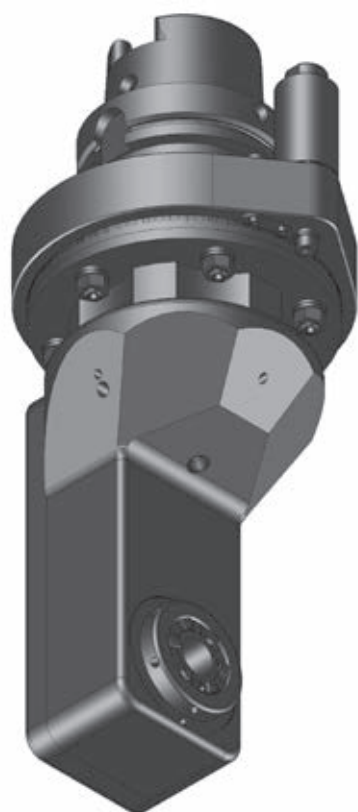

Size	Torque max.	Rev. max. (r.p.m.)	Gear Ratio	L mm	L1 mm	L2 mm	H mm	A mm	kg	SW
0	6 Nm	12.000	i = 1:1,67	237,5	38	20	36	80	11,0	18
5	30 Nm	8.000	i = 1:1	225,0	76	28	56	80	12,5	18
7	70 Nm	6.500	i = 1:1	295,0	100	38	80	80	13,5	18

Size	Toolholder	Clearance dia. E mm		L3 mm		L4 mm		Order No.		
		without coolant	with coolant	without coolant	with coolant	without coolant	with coolant	without coolant	external coolant	internal coolant
0	ER 11	50		49		-8,0		135592		
5	ER 25	82	82	65	65	10,0	10,0	135651	105683	
5	mi 40	125	125	65	65	23,5	23,5	173542	162941	
7	ER 32	102	102	66	66	13,0	13,0	135656	162928	
7	mi 50	135	135	66	66	29,0	29,0	105687	169062	

**HSK 100** **WS**

**Angle Head, Adjustable 0-98°**

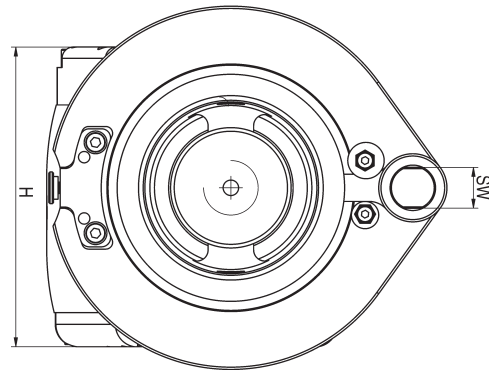
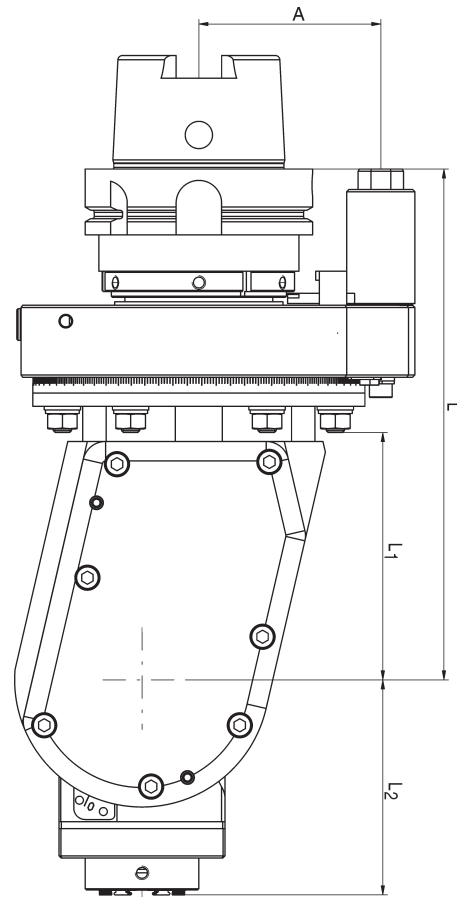
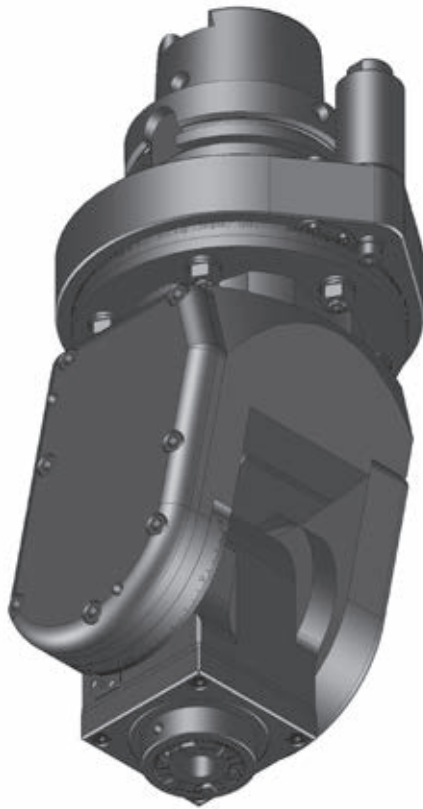
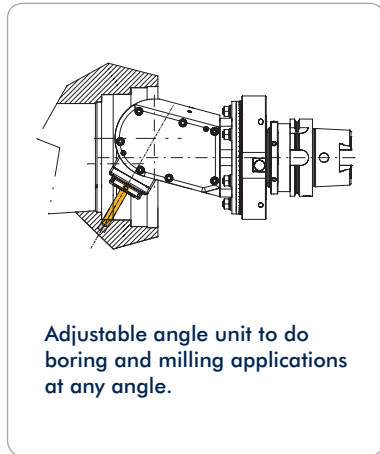

12

Size	Torque max.	Rev. max. (r.p.m.)	Gear Ratio	L mm	L1 mm	H mm	A mm	kg	SW
5	30 Nm	7.000 / 13.500	i = 1:1 / 1:2,25	205	96	111	80	14,0	18
7	70 Nm	6.000	i = 1:1	225	109	132	80	16,0	18

Size	Toolholder	L2 mm	L4 mm	Order No. (i=1:1)		Order No. (i=1:2,25)	
				without coolant	internal coolant	without coolant	internal coolant
5	ER 25	84	25	162976	135865	162977	162978
5	mi 40	97	25	162979	169980	162980	162981
7	ER 32	95	25	162986	105866		
7	mi 50	108	25	162991	169942		

**MAS-BT 40**

**SW**

## Angle Head 90°

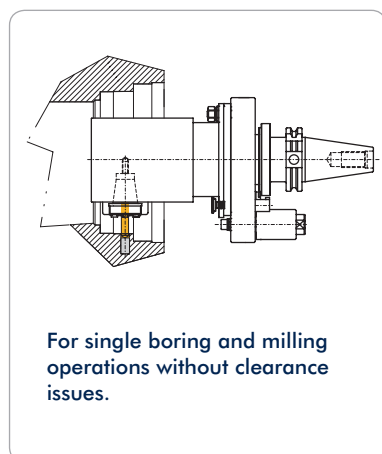

For single boring and milling operations without clearance issues.



**Attention!**  
Reversal of rotation direction

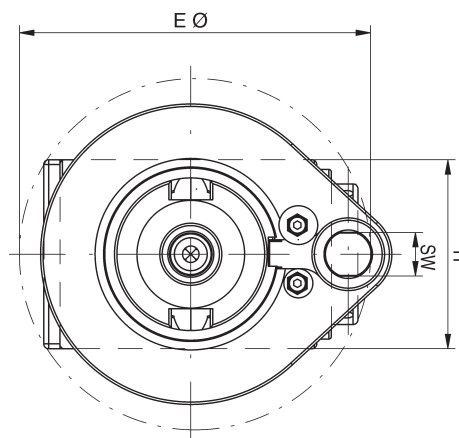
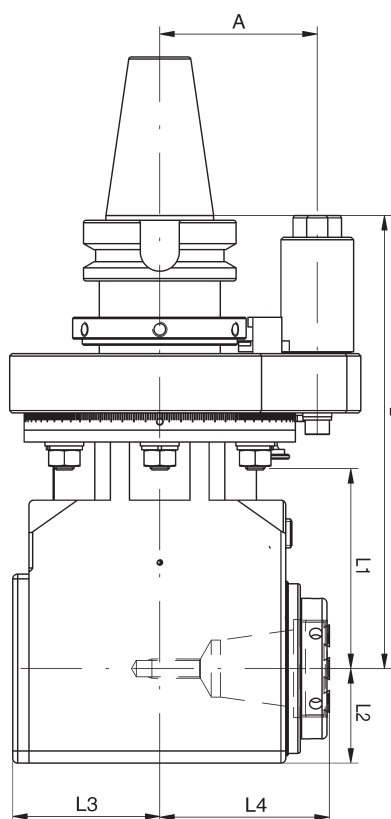
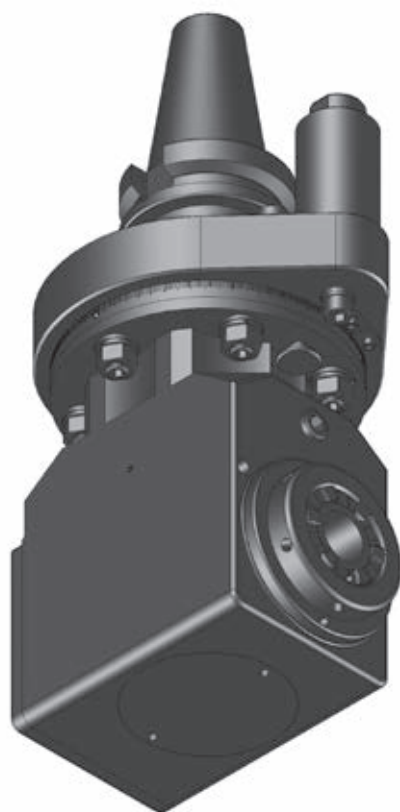

Size	Torque max.	Rev. max. (r.p.m.)	Gear Ratio	L mm	L1 mm	L2 mm	H mm	A mm	kg	SW
1	12 Nm	10.000	i = 1:1	187	80	22	44	65	6,0	18
5	30 Nm	8.000	i = 1:1	187	80	34	68	65	6,5	18
7	70 Nm	6.500	i = 1:1	187	80	39	78	65	8,0	18

Size	Toolholder	Clearance dia. E mm		L3 mm		L4 mm		Order No.		
		without coolant	with coolant	without coolant	with coolant	without coolant	with coolant	without coolant	external coolant	internal coolant
1	ER 16	91	96	29,0	44	45,0	50	135431	135444	135451
5	ER 25	110	120	41,5	52	57,5	63	135459	105503	135435
5	mi 40	138	146	41,5	52	72,0	72	173000	162802	162803
7	ER 32	145	155	61,0	75	70,0	75	135470	162777	105505
7	mi 50	172	178	61,0	75	83,0	83	170653	176278	167889



**MAS-BT 40**

**DW**

## Double Angle Head 90°

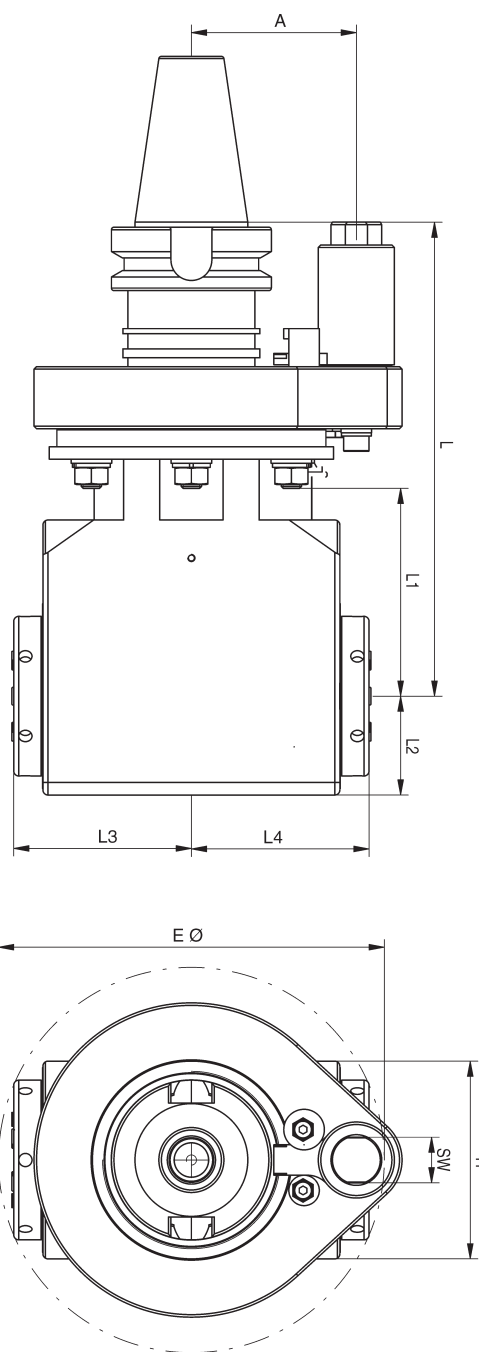
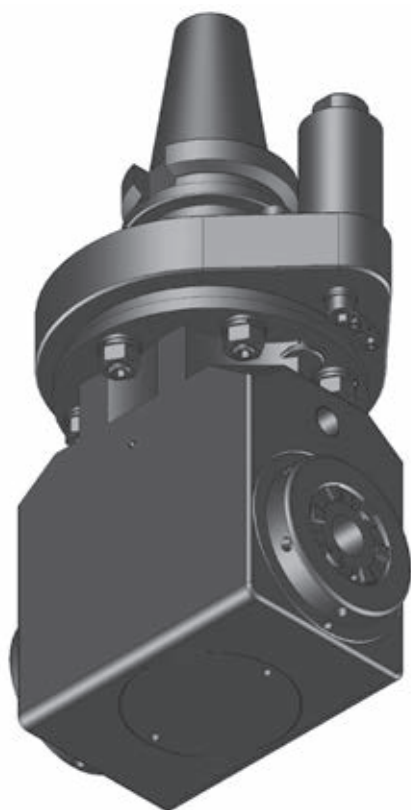
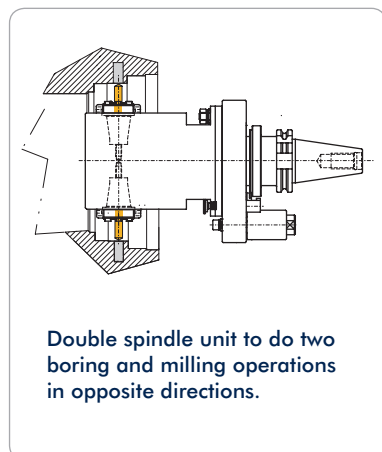

Size	Torque max.	Rev. max. (r.p.m.)	Gear Ratio	L mm	L1 mm	L2 mm	H mm	A mm	kg	SW
5	30 Nm	8.000	i = 1:1	187	80	39	78	65	7,5	18
7	70 Nm	6.500	i = 1:1	187	80	39	78	65	8,5	18

Size	Toolholder	Clearance dia. E mm		L3 mm		L4 mm		Order No.		
		without coolant	with coolant	without coolant	with coolant	without coolant	with coolant	without coolant	external coolant	internal coolant
5	2 x ER 25	125	125	62,0	62,0	62,0	62,0	135717	162823	
5	2 x mi 32	200	200	76,5	76,5	76,5	76,5	173509	162840	
7	2 x ER 32	152	152	71,2	71,2	71,2	71,2	135729	162829	
7	2 x mi 40	220	220	88,0	88,0	88,0	88,0	173516	162847	

12

**MAS-BT 40**

**ZW**

## Angle Head 90°, Offset Type

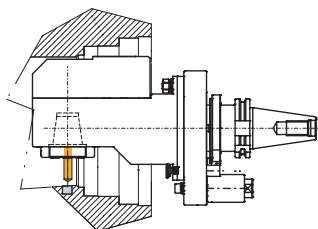

Rear offset unit with increased usable tool length and internal coolant is an option.

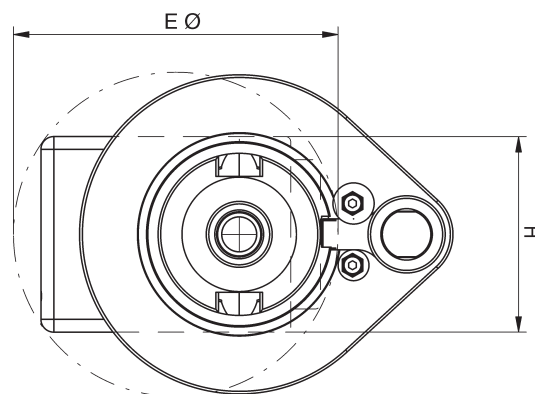
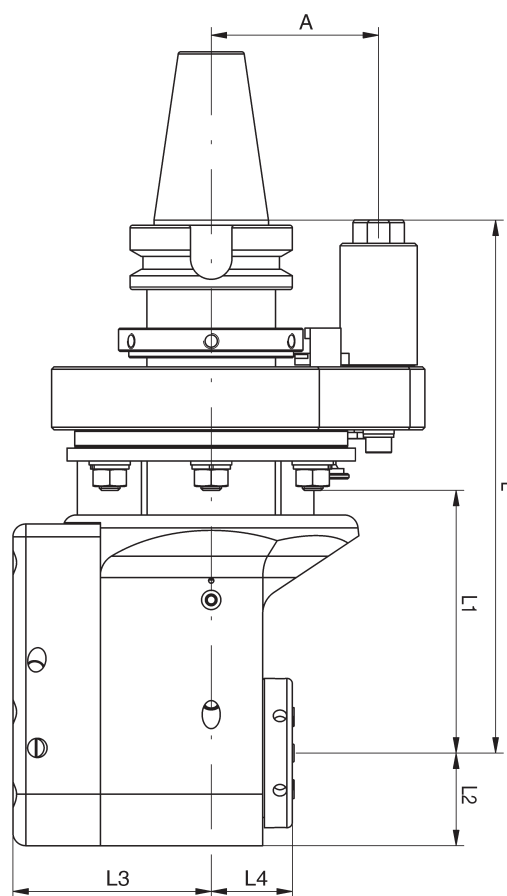
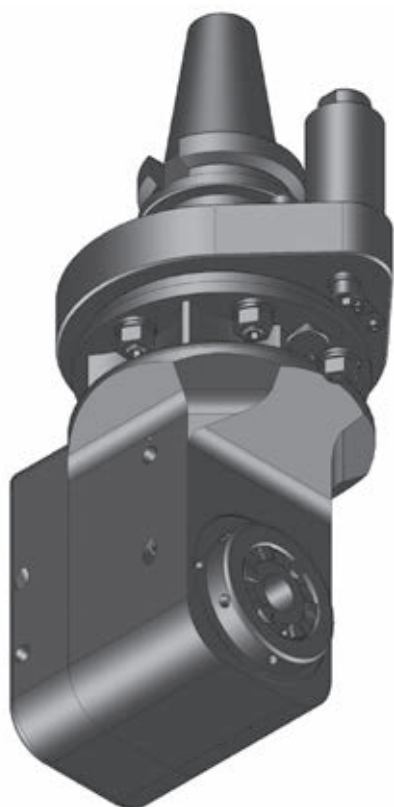

Size	Torque max.	Rev. max. (r.p.m.)	Gear Ratio	L mm	L1 mm	L2 mm	H mm	A mm	kg	SW
5	30 Nm	8.000	i = 1:1	187	80	28,5	57	65	6,5	18
7	70 Nm	6.000	i = 1:1	205	100	38,0	76	65	8,5	18

Size	Toolholder	Clearance dia. E mm		L3 mm		L4 mm		Order No.		
		without coolant	with coolant	without coolant	with coolant	without coolant	with coolant	without coolant	external coolant	internal coolant
5	ER 25	103	103	57,0	57,0	35,8	41,6	105435	162857	162859
5	mi 40	130	130	57,0	57,0	50,3	50,3	105458	162882	162883
7	ER 32	128	128	77,5	77,5	32,2	38,0	105477	162870	172498
7	mi 50	150	150	77,5	77,5	55,0	55,0	173527	162897	162898

**MAS-BT 40 ZWS**

**Angle Head 90°, Offset Slim Type**

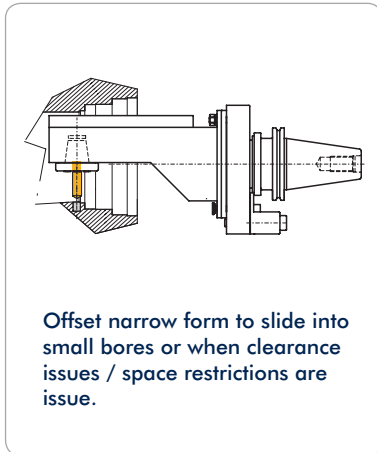

**Attention!**  
Reversal of rotation direction

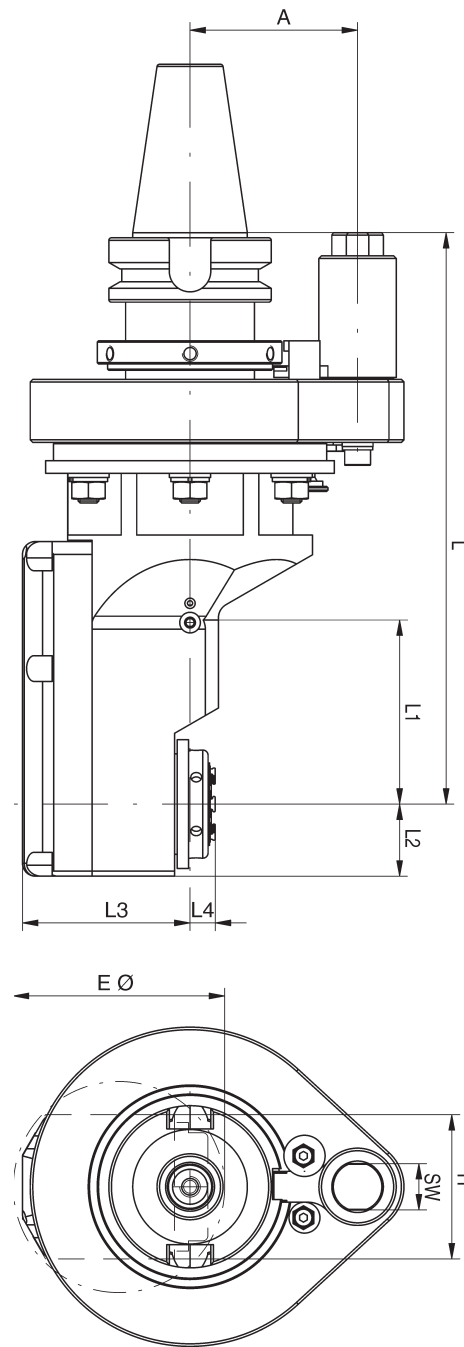
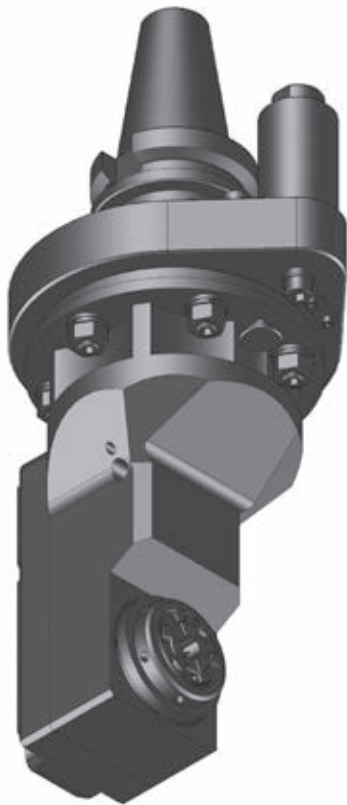

Size	Torque max.	Rev. max. (r.p.m.)	Gear Ratio	L mm	L1 mm	L2 mm	H mm	A mm	kg	SW
0	6 Nm	12.000	i = 1:1,67	220	38	20	36	65	7,0	18
3	15 Nm	10.000	i = 1:1	232	80	24	48	65	6,0	18
5	30 Nm	8.000	i = 1:1	222	76	28	56	65	6,5	18

Size	Toolholder	Clearance dia. E mm		L3 mm		L4 mm		Order No.		
		without coolant	with coolant	without coolant	with coolant	without coolant	with coolant	without coolant	external coolant	internal coolant
0	ER 11	50		49,0		-8,0		105651		
3	ER 20	75		54,5		11,2		135629		
3	mi 32	100		54,5		26,0		173536		
5	ER 25	82	82	65,0	65,0	10,0	10,0	135649	162924	
5	mi 40	125	125	65,0	65,0	23,5	23,5	173537	162936	

**MAS-BT 40** **WS**

**Angle Head, Adjustable 0-98°**

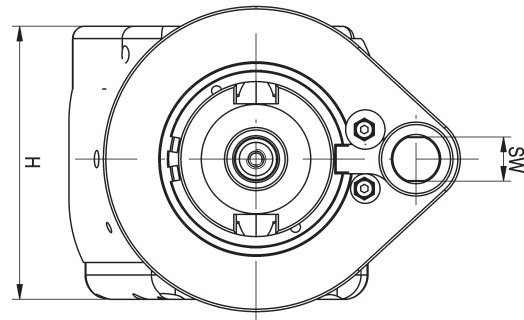
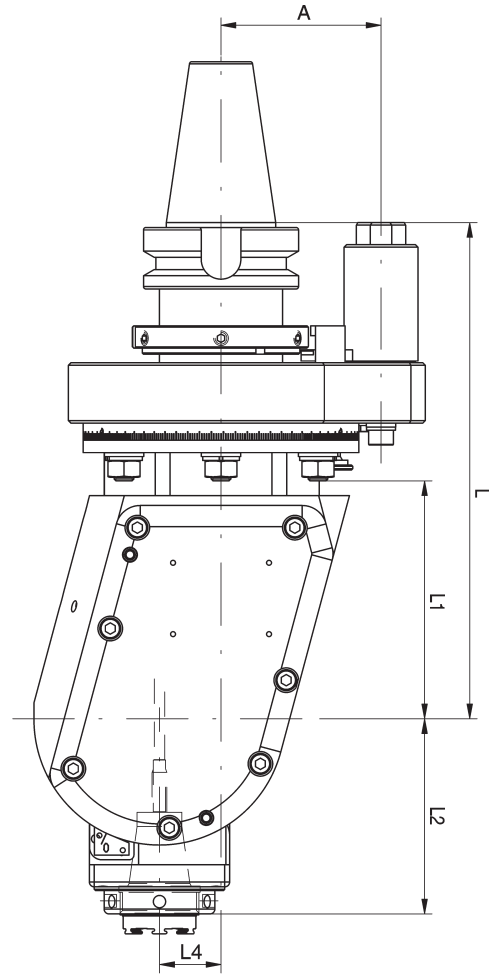
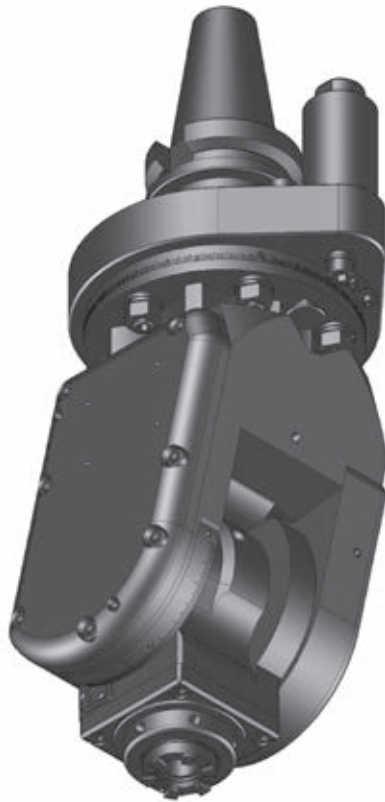
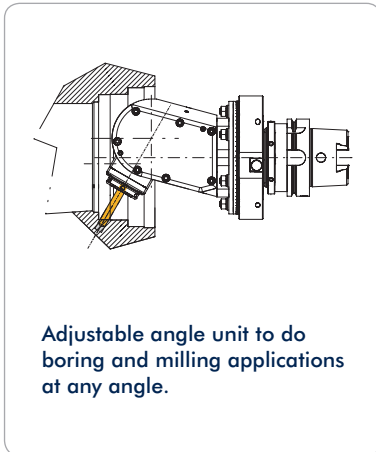

Size	Torque max.	Rev. max. (r.p.m.)	Gear Ratio	L mm	L1 mm	H mm	A mm	kg	SW
3	15 Nm	8.000 / 15.000	i = 1:1 / 1:2,25	196	100	96	65	8,0	18
5	30 Nm	7.000 / 13.500	i = 1:1 / 1:2,25	202	100	111	65	9,6	18

Size	Toolholder	L2 mm	L4 mm	Order No. (i=1:1)		Order No. (i=1:2,25)	
				without coolant	internal coolant	without coolant	internal coolant
3	ER 20	75,0	20	173907	105808	162858	162933
3	mi 32	82,9	20	156569	167418	156570	156574
5	ER 25	84,0	25	162955	135813	162957	162956
5	mi 40	97,0	25	162958	169976	162959	162960

**MAS-BT 50**

**SW**

## Angle Head 90°

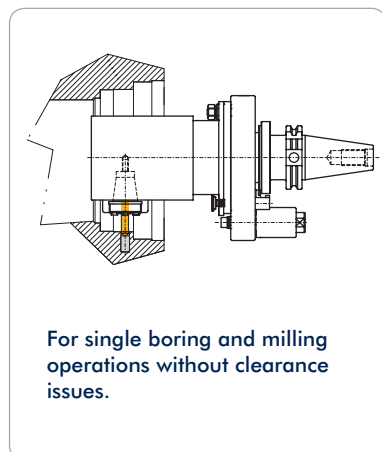

For single boring and milling operations without clearance issues.



**Attention!**  
Reversal of rotation direction

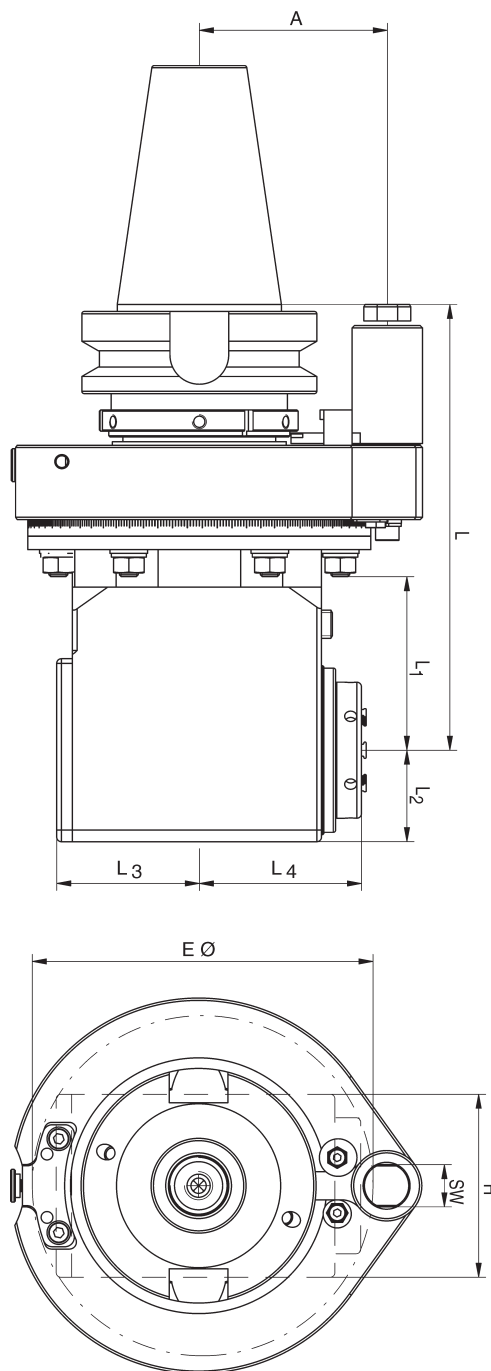
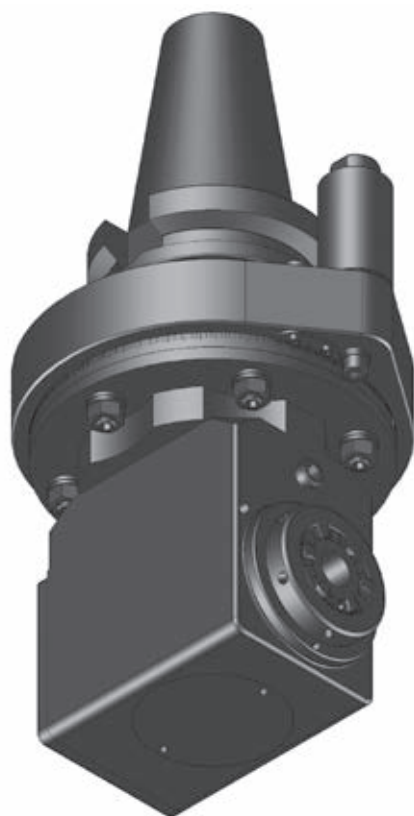

Size	Torque max.	Rev. max. (r.p.m.)	Gear Ratio	L mm	L1 mm	L2 mm	H mm	A mm	kg	SW
5	30 Nm	8.000	i = 1:1	190	75	34	68	80	10,5	18
7	70 Nm	6.500	i = 1:1	190	75	39	78	80	12,0	18
9	150 Nm	5.000	i = 1:1	225	109	52	104	80	18,0	18

Size	Toolholder	Clearance dia. E mm		L3 mm		L4 mm		Order No.		
		without coolant	with coolant	without coolant	with coolant	without coolant	with coolant	without coolant	external coolant	internal coolant
5	ER 25	110	120	41,5	52	57,5	63,0	105494	162772	162773
5	mi 40	138	146	41,5	52	72,0	72,0	173014	162809	162810
7	ER 32	145	155	61,0	75	70,0	75,0	135482	105538	172558
7	mi 50	172	178	61,0	75	83,0	83,0	105520	105508	174169
9	ER 40	195	195	81,0	81	92,0	96,0	105512	162783	167210
9	mi 63	224	224	81,0	81	111,5	111,5	167208	162787	167211

**MAS-BT 50**

**DW**

## Double Angle Head 90°

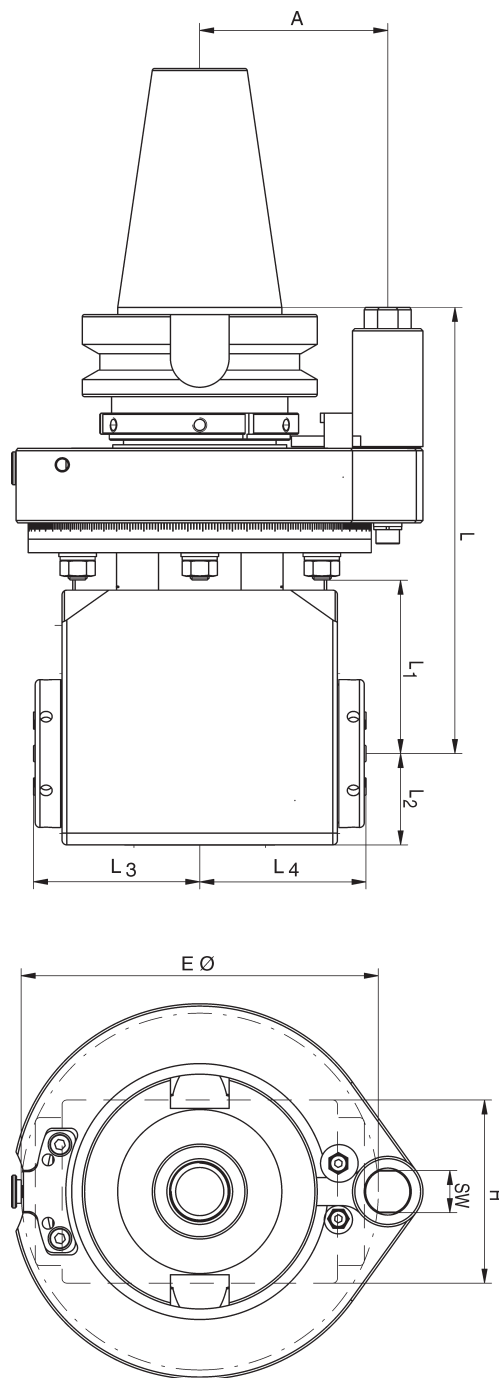
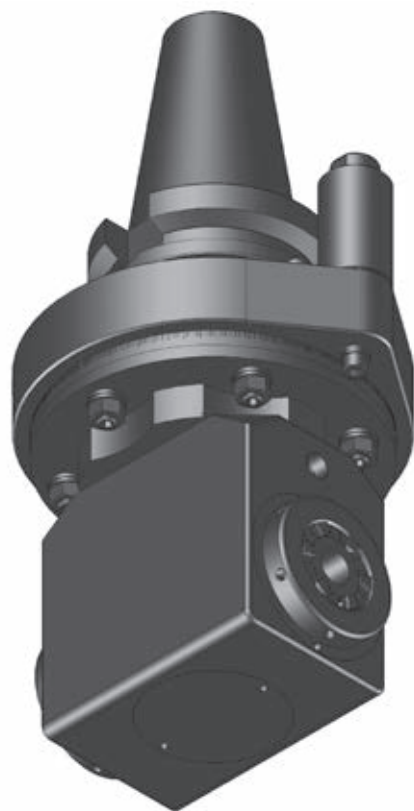
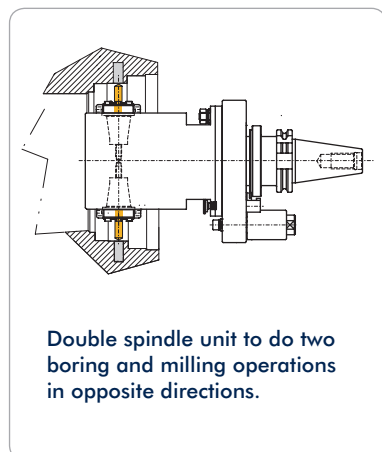

Size	Torque max.	Rev. max. (r.p.m.)	Gear Ratio	L mm	L1 mm	L2 mm	H mm	A mm	kg	SW
5	30 Nm	8.000	i = 1:1	190	70	34	68	80	11,5	18
7	70 Nm	6.500	i = 1:1	190	70	39	78	80	13,5	18
9	150 Nm	4.000	i = 1:1	225	109	58	108	80	20,0	18

Size	Toolholder	Clearance dia. E mm		L3 mm		L4 mm		Order No.		
		without coolant	with coolant	without coolant	with coolant	without coolant	with coolant	without coolant	external coolant	internal coolant
5	2 x ER 25	125	125	62,0	62,0	62,0	62,0	135691	162826	
5	2 x mi 32	200	200	76,5	76,5	76,5	76,5	173513	162844	
7	2 x ER 32	152	152	71,2	71,2	71,2	71,2	135724	162832	
7	2 x mi 40	220	220	88,0	88,0	88,0	88,0	173518	162849	
9	2 x ER 40	210	210	103,0	103,0	103,0	103,0	105788	162836	
9	2 x mi 50	250	250	116,0	116,0	116,0	116,0	173520	162853	

**MAS-BT 50 ZW**

**Angle Head 90°, Offset Type**

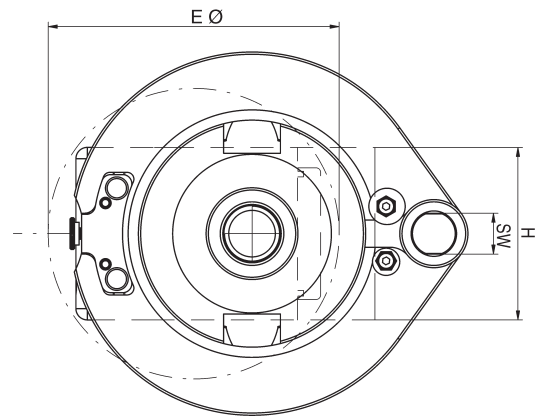
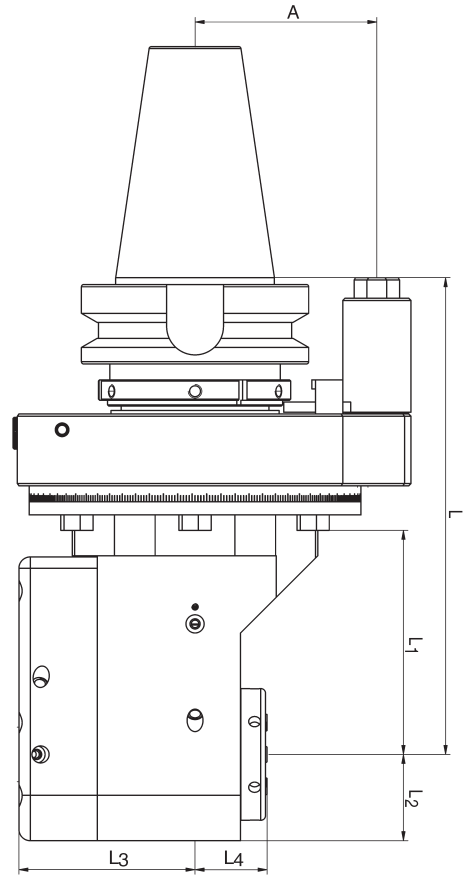
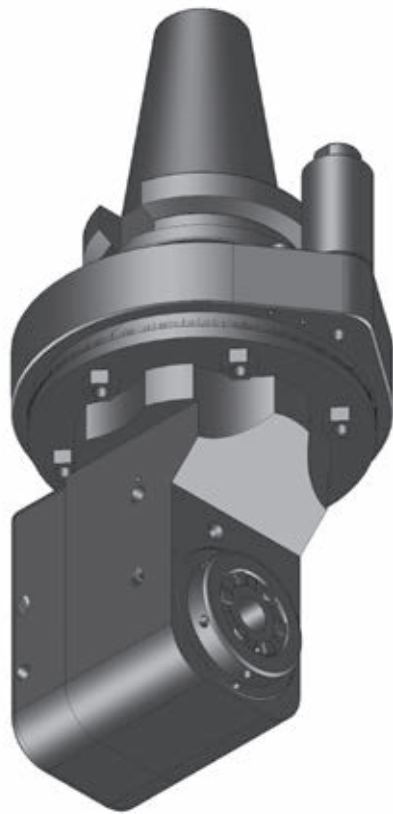
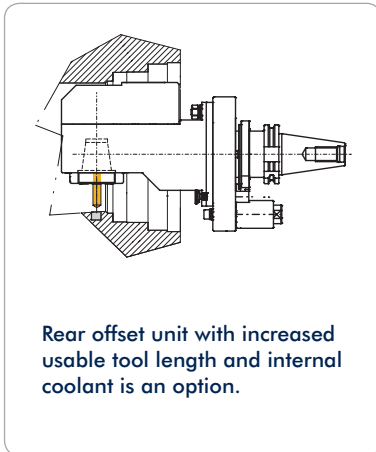

Size	Torque max.	Rev. max. (r.p.m.)	Gear Ratio	L mm	L1 mm	L2 mm	H mm	A mm	kg	SW
5	30 Nm	8.000	i = 1:1	195	79	28,5	57	80	11,5	18
7	70 Nm	6.000	i = 1:1	210	94	38,0	76	80	14,0	18
9	150 Nm	5.000	i = 1:1	270	110	52,0	104	80	19,0	18

Size	Toolholder	Clearance dia. E mm		L3 mm		L4 mm		Order No.		
		without coolant	with coolant	without coolant	with coolant	without coolant	with coolant	without coolant	external coolant	internal coolant
5	ER 25	103	103	57,0	57,0	35,8	41,6	105417	162865	162866
5	mi 40	133	133	57,0	57,0	50,3	50,3	173525	162891	171760
7	ER 32	128	128	77,5	77,5	32,2	38,0	105460	162944	174661
7	mi 50	152	152	77,5	77,5	55,0	55,0	173531	162902	135378
9	ER 40	140	140	89,0	89,0	31,0	34,8	105470	168456	162878
9	mi 63	165	165	89,0	89,0	48,3	48,3	173533	162908	162909

**MAS-BT 50 ZWS**

**Angle Head 90°, Offset Slim Type**

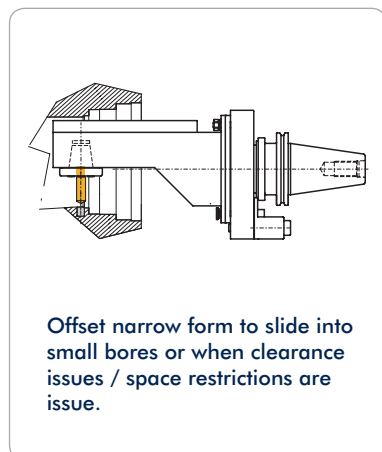

**Attention!**  
Reversal of rotation direction

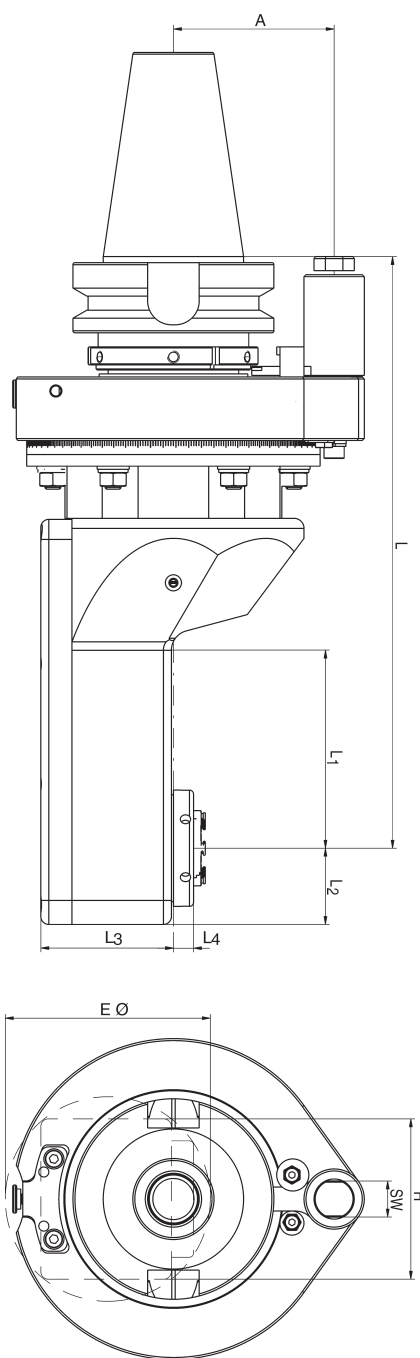
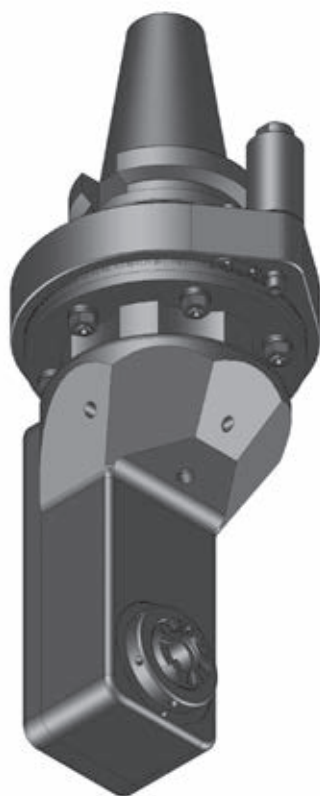

Size	Torque max.	Rev. max. (r.p.m.)	Gear Ratio	L mm	L1 mm	L2 mm	H mm	A mm	kg	SW
0	6 Nm	12.000	i = 1:1,67	237,5	38	20	36	80	11,0	18
5	30 Nm	8.000	i = 1:1	225,0	76	28	56	80	12,5	18
7	70 Nm	6.000	i = 1:1	295,0	100	38	80	80	13,5	18

Size	Toolholder	Clearance dia. E mm		L3 mm		L4 mm		Order No.		
		without coolant	with coolant	without coolant	with coolant	without coolant	with coolant	without coolant	external coolant	internal coolant
0	ER 11	50		49		-8,0		105652		
5	ER 25	82	82	65	65	10,0	10,0	135650	168453	
5	mi 40	125	125	65	65	23,5	23,5	173541	162940	
7	ER 32	102	102	66	66	13,0	13,0	105698	168454	
7	mi 50	135	135	66	66	29,0	29,0	173544	168460	



**MAS-BT 50**

**WS**

## Angle Head, Adjustable 0-98°

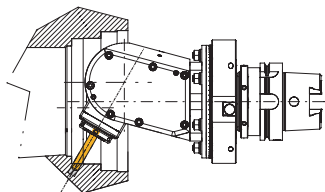

Adjustable angle unit to do boring and milling applications at any angle.

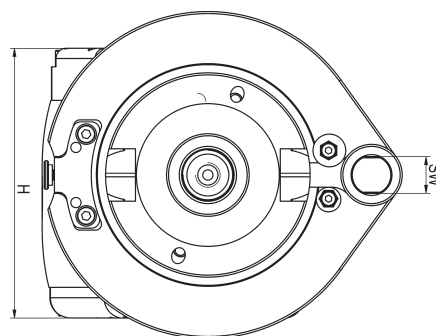
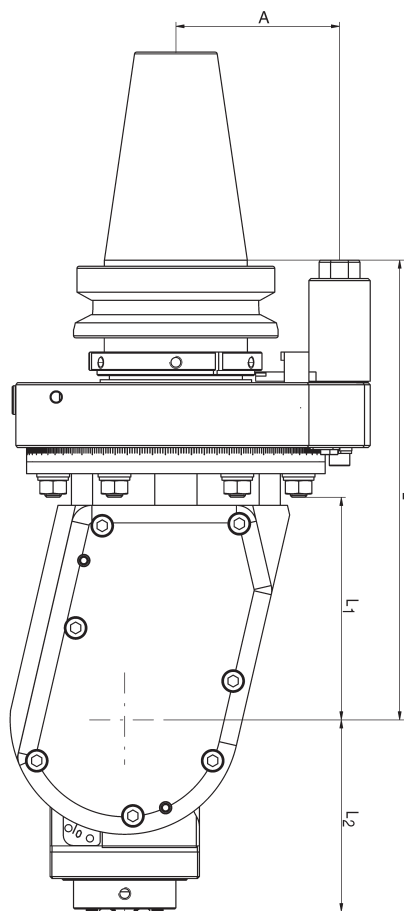
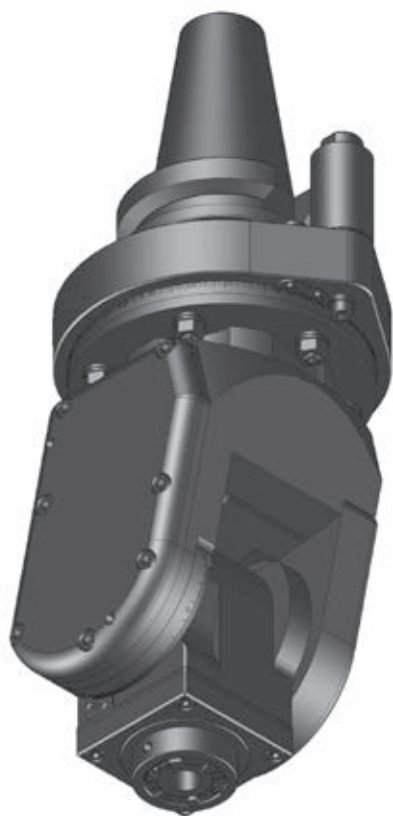

Size	Torque max.	Rev. max. (r.p.m.)	Gear Ratio	L mm	L1 mm	H mm	A mm	kg	SW
5	30 Nm	7.000 / 13.500	i = 1:1 / 1:2,25	205	100	111	80	14,0	18
7	70 Nm	6.000	i = 1:1	225	109	132	80	16,0	18

Size	Toolholder	L2 mm	L4 mm	Order No. (i=1:1)		Order No. (i=1:2,25)	
				without coolant	internal coolant	without coolant	internal coolant
5	ER 25	84	25	162970	105830	162972	162971
5	mi 40	97	25	162973	169979	162975	162974
7	ER 32	95	25	162985	105859		
7	mi 50	108	25	162988	167553		

**ANSI CAT 40 SW**

**Angle Head 90°**

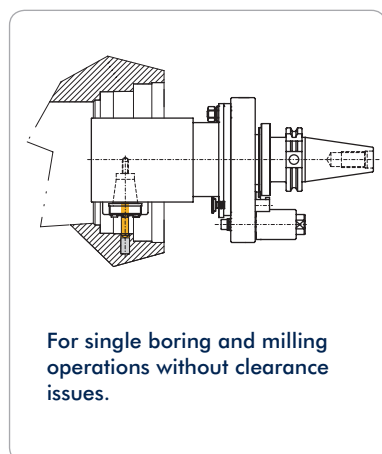

For single boring and milling operations without clearance issues.



**Attention!**  
Reversal of rotation direction

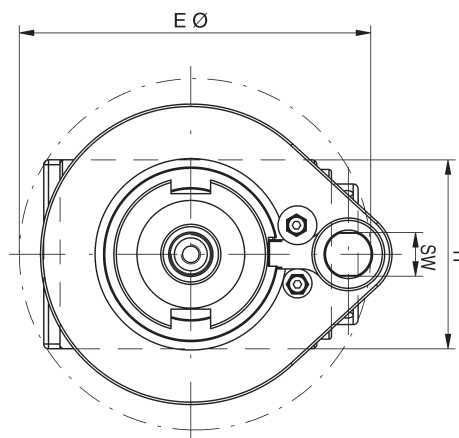
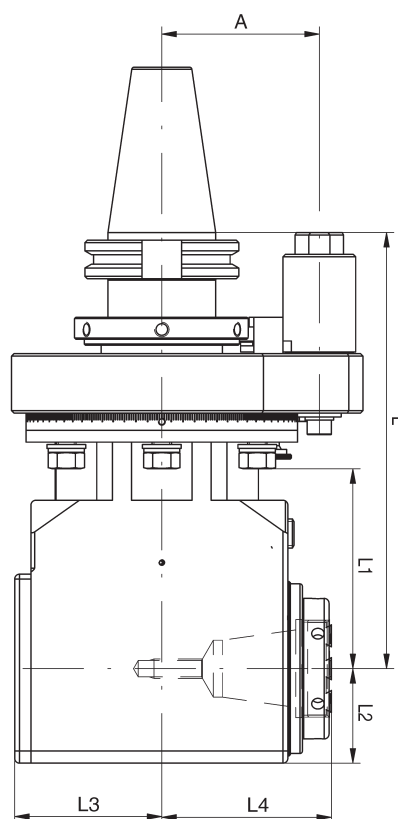

Size	Torque max.	Rev. max. (r.p.m.)	Gear Ratio	L mm	L1 mm	L2 mm	H mm	A mm	kg	SW
1	12 Nm	10.000	i = 1:1	180	80	22	44	65	6,0	18
5	30 Nm	8.000	i = 1:1	180	80	34	68	65	6,5	18
7	70 Nm	6.500	i = 1:1	180	80	39	78	65	8,0	18

Size	Toolholder	Clearance dia. E mm		L3 mm		L4 mm		Order No.		
		without coolant	with coolant	without coolant	with coolant	without coolant	with coolant	without coolant	external coolant	internal coolant
1	ER 16	91	96	29,0	44	45,0	50	135465	162769	162776
5	ER 25	110	120	41,5	52	57,5	63	135432	183182	176443
5	mi 40	138	146	41,5	52	72,0	72	169839	173031	176540
7	ER 32	145	155	61,0	75	70,0	75	135477	162775	176444
7	mi 50	172	178	61,0	75	83,0	83	135485	105509	166537

**ANSI CAT 40 DW**

**Double Angle Head 90°**

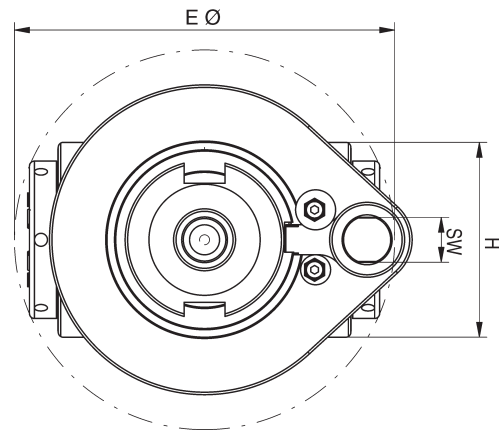
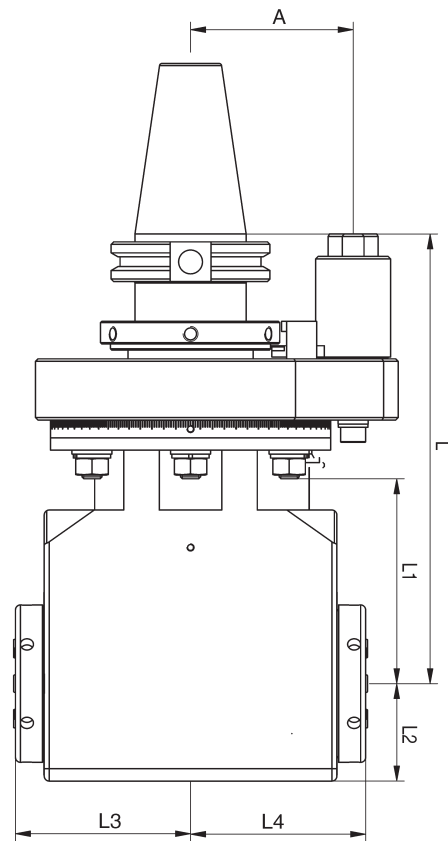
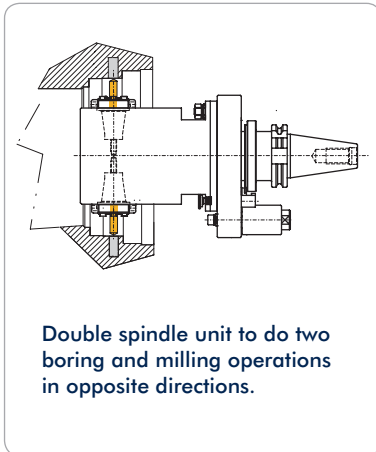

12

Size	Torque max.	Rev. max. (r.p.m.)	Gear Ratio	L mm	L1 mm	L2 mm	H mm	A mm	kg	SW
5	30 Nm	8.000	i = 1:1	180	80	39	78	65	7,5	18
7	70 Nm	6.500	i = 1:1	180	80	39	78	65	8,5	18

Size	Toolholder	Clearance dia. E mm		L3 mm		L4 mm		Order No.		
		without coolant	with coolant	without coolant	with coolant	without coolant	with coolant	without coolant	external coolant	internal coolant
5	2 x ER 25	125	125	62,0	62,0	62,0	62,0	135696	162822	
5	2 x mi 32	210	210	92,0	76,5	76,5	76,5	173508	162839	
7	2 x ER 32	152	152	71,2	71,2	71,2	71,2	135720	162828	
7	2 x mi 40	220	220	88,0	88,0	88,0	88,0	173515	162846	

**ANSI CAT 40 ZW**

**Angle Head 90°, Offset Type**

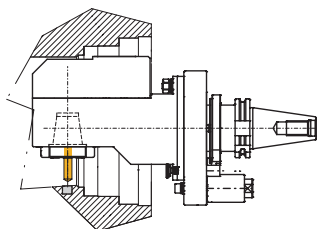

Rear offset unit with increased usable tool length and internal coolant is an option.

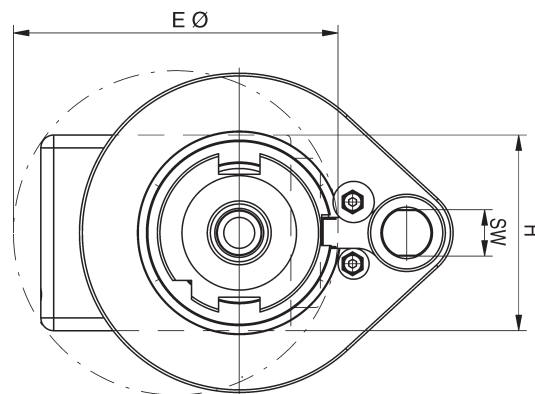
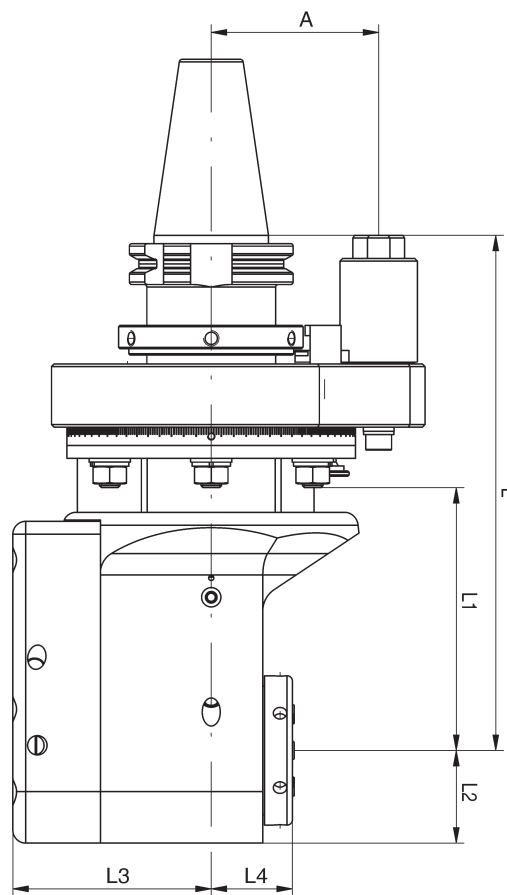
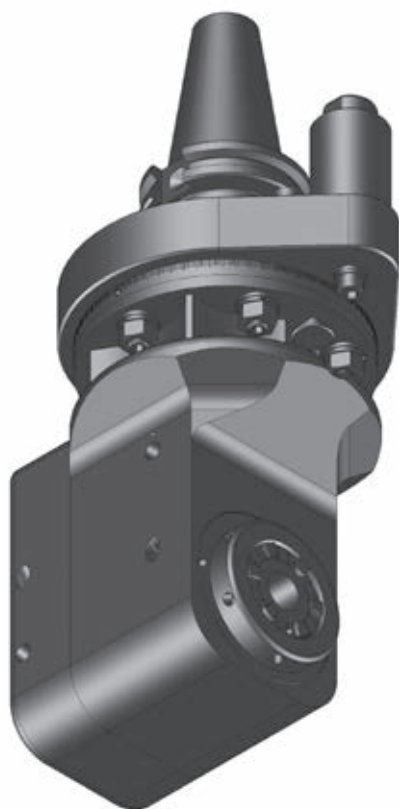

Size	Torque max.	Rev. max. (r.p.m.)	Gear Ratio	L mm	L1 mm	L2 mm	H mm	A mm	kg	SW
5	30 Nm	8.000	i = 1:1	180	80	28,5	57	65	6,5	18
7	70 Nm	6.000	i = 1:1	198	100	38,0	76	65	8,5	18

Size	Toolholder	Clearance dia. E mm		L3 mm		L4 mm		Order No.		
		without coolant	with coolant	without coolant	with coolant	without coolant	with coolant	without coolant	external coolant	internal coolant
5	ER 25	103	103	57,0	57,0	35,8	41,6	135401	162856	135415
5	mi 40	130	130	57,0	57,0	50,3	50,3	173521	162881	105451
7	ER 32	128	128	77,5	77,5	32,2	38,0	135391	162869	135417
7	mi 50	150	150	77,5	77,5	55,0	55,0	173526	162896	166538

**ANSI CAT 40 ZWS**

**Angle Head 90°, Offset Slim Type**

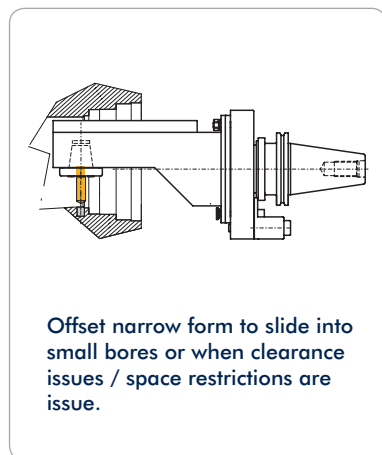

**Attention!**  
Reversal of rotation direction

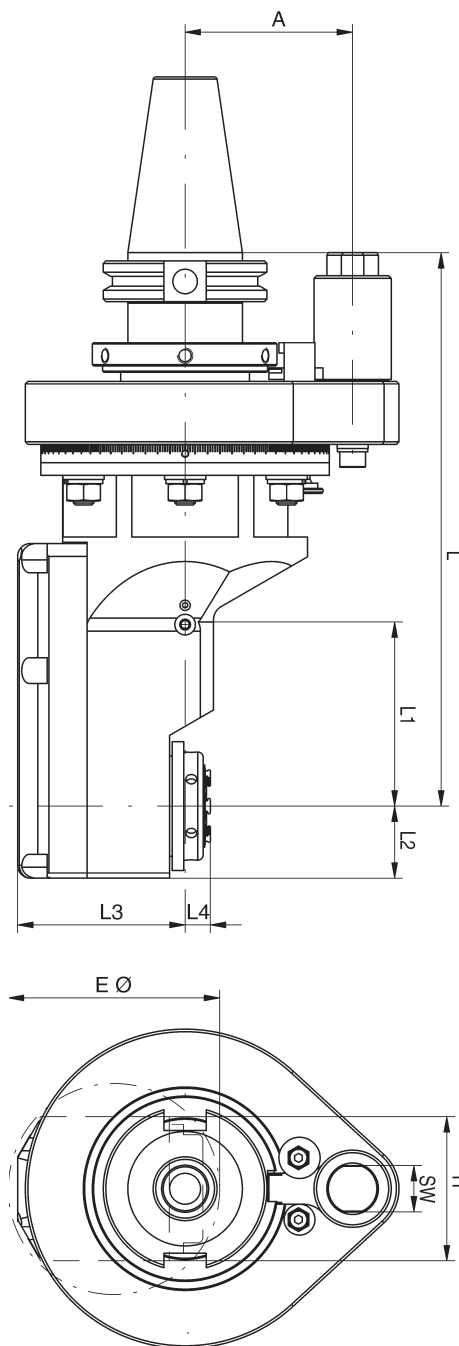
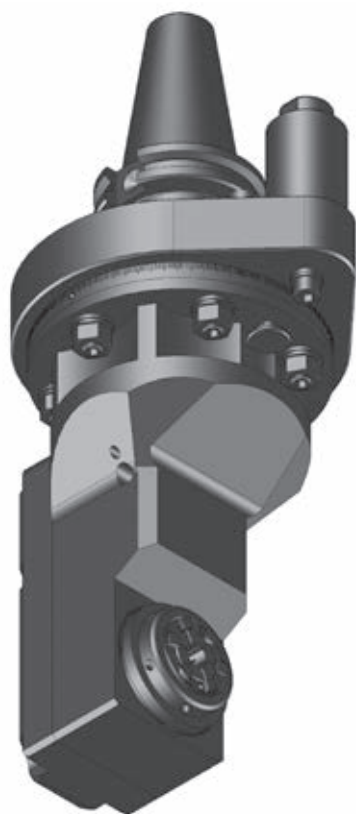

Size	Torque max.	Rev. max. (r.p.m.)	Gear Ratio	L mm	L1 mm	L2 mm	H mm	A mm	kg	SW
0	6 Nm	12.000	i = 1:1,67	213	38	20	36	65	7,0	18
3	15 Nm	10.000	i = 1:1	225	80	24	48	65	6,0	18
5	30 Nm	8.000	i = 1:1	215	76	28	56	65	6,5	18

Size	Toolholder	Clearance dia. E mm		L3 mm		L4 mm		Order No.		
		without coolant	with coolant	without coolant	with coolant	without coolant	with coolant	without coolant	external coolant	internal coolant
0	ER 11	50		49,0		-8,0		135613		
3	ER 20	75		54,5		11,2		135614		
3	mi 32	100		54,5		26,0		162929		
5	ER 25	82	82	65,0	65,0	10,0	10,0	135619	162923	
5	mi 40	125	125	65,0	65,0	23,5	23,5	173538	162935	

**ANSI CAT 40 WS**

**Angle Head, Adjustable 0-98°**

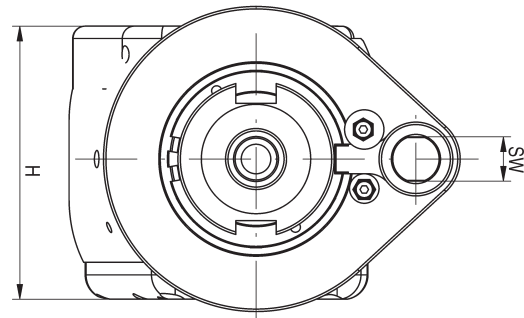
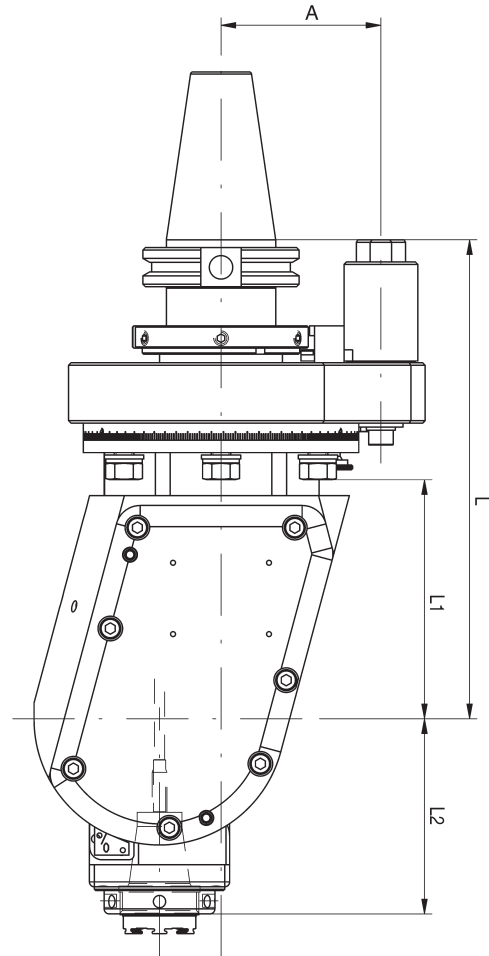
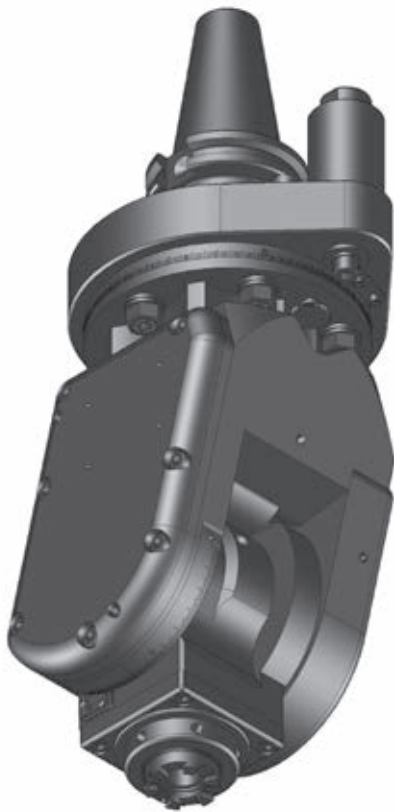
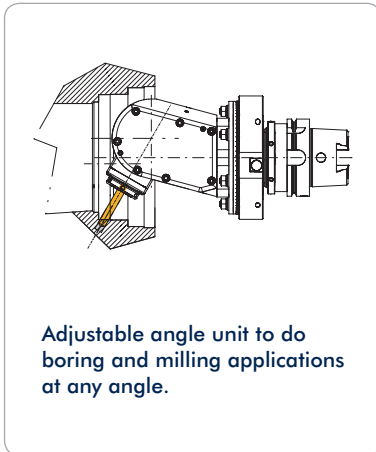

Size	Torque max.	Rev. max. (r.p.m.)	Gear Ratio	L mm	L1 mm	H mm	A mm	kg	SW
3	15 Nm	8.000 / 15.000	i = 1:1 / 1:2,25	189	91	96	65	8,0	18
5	30 Nm	7.000 / 13.500	i = 1:1 / 1:2,25	195	96	111	65	9,6	18

Size	Toolholder	L2 mm	L4 mm	Order No. (i=1:1)		Order No. (i=1:2,25)	
				without coolant	internal coolant	without coolant	internal coolant
3	ER 20	75,0	20	162797	135811	162800	162801
3	mi 32	82,9	20	156566	167896	156567	156568
5	ER 25	84,0	25	172227	135838	162717	135781
5	mi 40	97,0	25	162932	135817	162725	162724

**ANSI CAT 50 SW**

**Angle Head 90°**

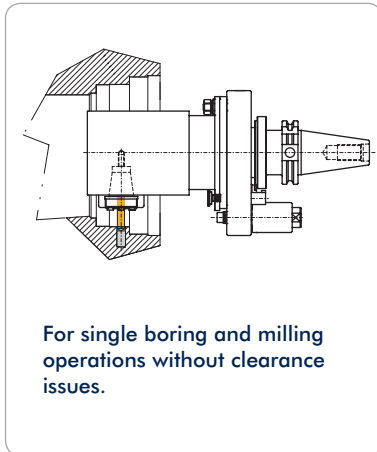

For single boring and milling operations without clearance issues.



**Attention!**  
Reversal of rotation direction

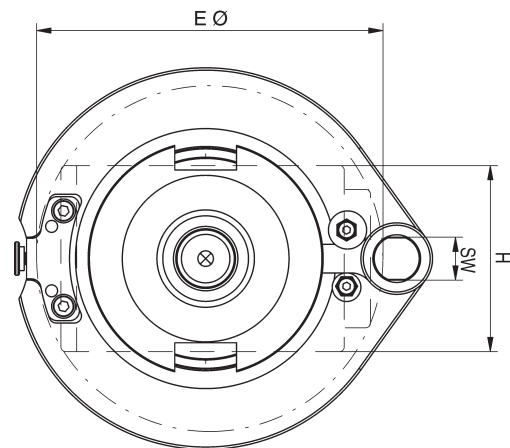
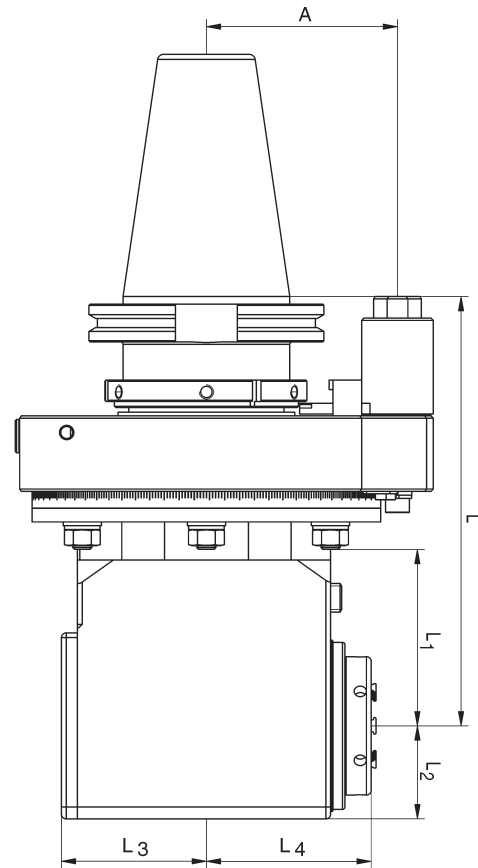
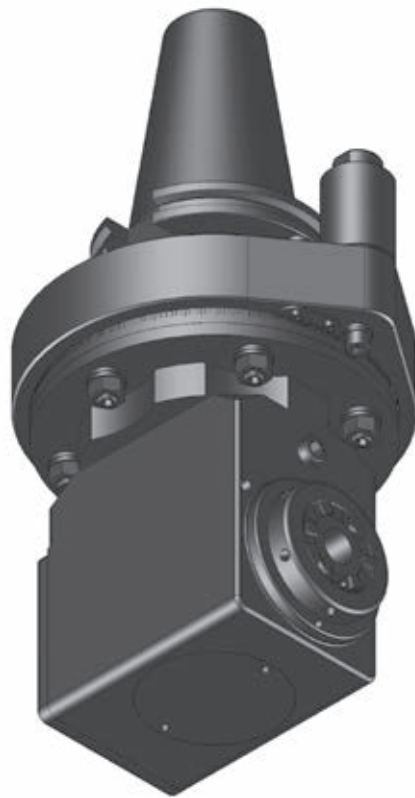

Size	Torque max.	Rev. max. (r.p.m.)	Gear Ratio	L mm	L1 mm	L2 mm	H mm	A mm	kg	SW
5	30 Nm	8.000	i = 1:1	180	75	34	68	80	10,5	18
7	70 Nm	6.500	i = 1:1	180	75	39	78	80	12,0	18
9	150 Nm	5.000	i = 1:1	215	105	52	104	80	18,0	18

Size	Toolholder	Clearance dia. E mm		L3 mm		L4 mm		Order No.		
		without coolant	with coolant	without coolant	with coolant	without coolant	with coolant	without coolant	external coolant	internal coolant
5	ER 25	110	120	41,5	52	57,5	63,0	135420	162770	162771
5	mi 40	138	146	41,5	52	72,0	72,0	173068	162807	162808
7	ER 32	145	155	61,0	75	70,0	75,0	135471	162779	172905
7	mi 50	172	178	61,0	75	83,0	83,0	135472	162796	105525
9	ER 40	195	195	81,0	81	92,0	96,0	105553	162781	162782
9	mi 63	224	224	81,0	81	111,5	111,5	173505	162785	162786

**ANSI CAT 50 DW**

**Double Angle Head 90°**

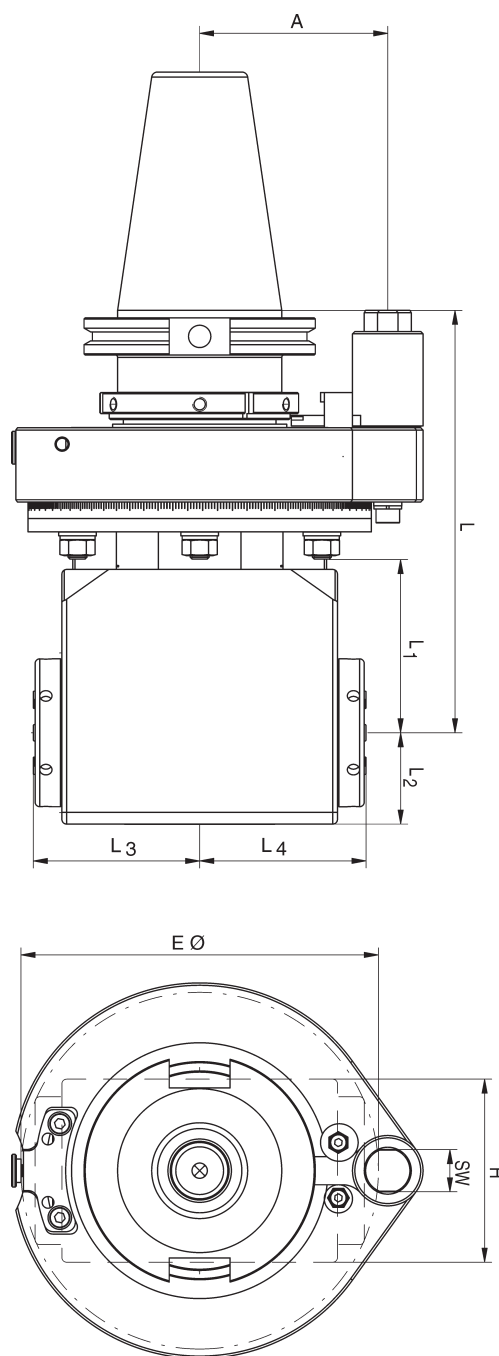
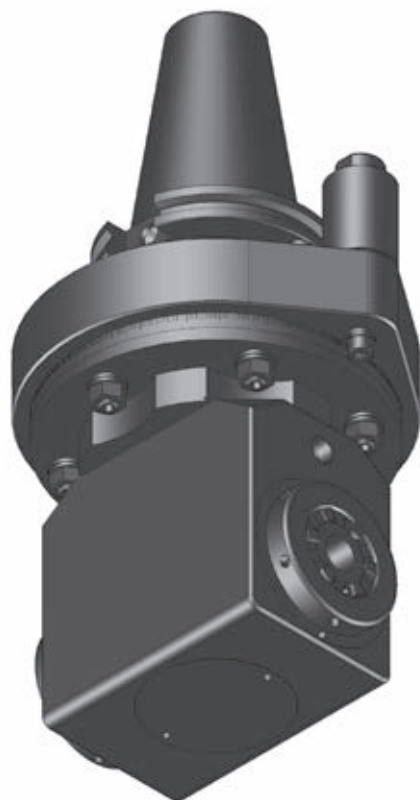
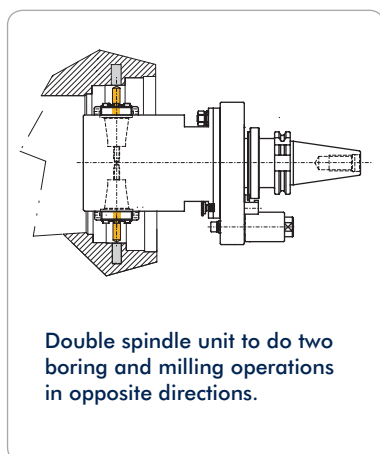

Size	Torque max.	Rev. max. (r.p.m.)	Gear Ratio	L mm	L1 mm	L2 mm	H mm	A mm	kg	SW
5	30 Nm	8.000	i = 1:1	180	70	34	68	80	11,5	18
7	70 Nm	6.500	i = 1:1	180	70	39	78	80	13,5	18
9	150 Nm	4.000	i = 1:1	215	109	58	108	80	20,0	18

Size	Toolholder	Clearance dia. E mm		L3 mm		L4 mm		Order No.		
		without coolant	with coolant	without coolant	with coolant	without coolant	with coolant	without coolant	external coolant	internal coolant
5	2 x ER 25	125	125	62,0	62,0	62,0	62,0	135723	135718	
5	2 x mi 32	200	200	76,5	76,5	76,5	76,5	173512	162843	
7	2 x ER 32	152	152	71,2	71,2	71,2	71,2	135725	162831	
7	2 x mi 40	220	220	88,0	88,0	88,0	88,0	173517	162848	
9	2 x ER 40	210	210	103,0	103,0	103,0	103,0	105789	162835	
9	2 x mi 50	250	250	116,0	116,0	116,0	116,0	173519	162852	



**ANSI CAT 50 ZW**

**Angle Head 90°, Offset Type**

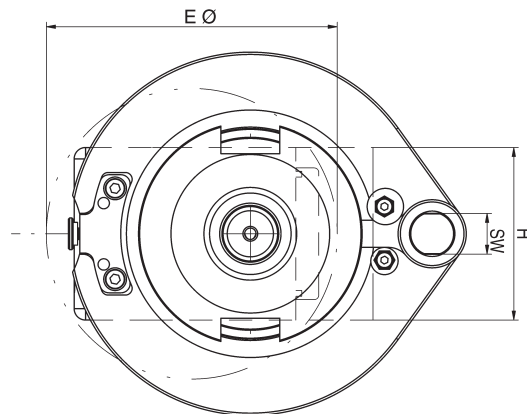
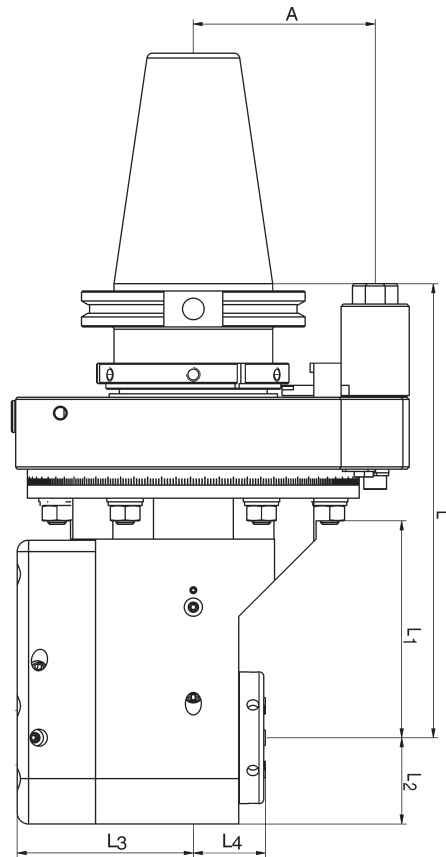
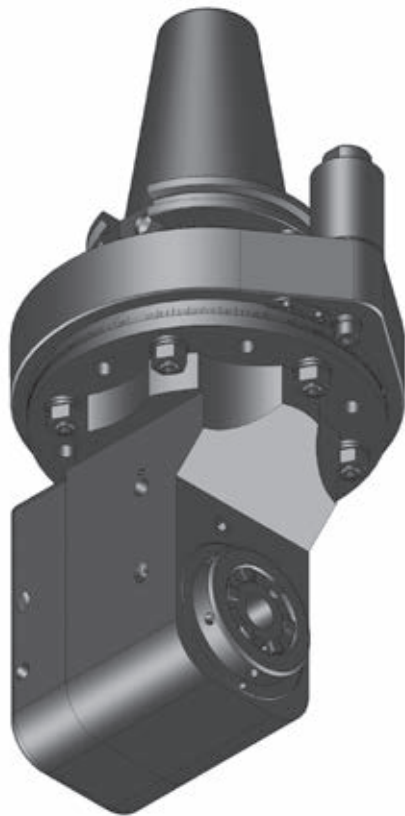
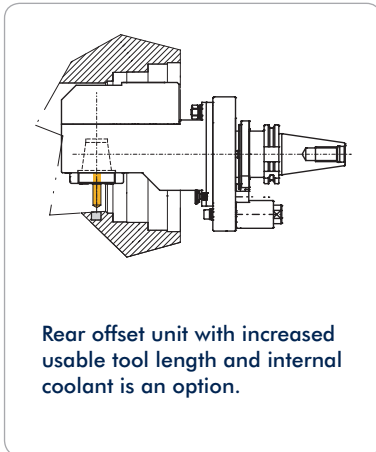

Size	Torque max.	Rev. max. (r.p.m.)	Gear Ratio	L mm	L1 mm	L2 mm	H mm	A mm	kg	SW
5	30 Nm	8.000	i = 1:1	185	79	28,5	57	80	11,5	18
7	70 Nm	6.000	i = 1:1	200	94	38,0	78	80	14,0	18
9	150 Nm	5.000	i = 1:1	260	152	52,0	104	80	19,0	18

Size	Toolholder	Clearance dia. E mm		L3 mm		L4 mm		Order No.		
		without coolant	with coolant	without coolant	with coolant	without coolant	with coolant	without coolant	external coolant	internal coolant
5	ER 25	103	103	58,0	58,0	35,8	41,6	135371	162863	162864
5	mi 40	133	133	58,0	58,0	50,3	50,3	173524	162888	167846
7	ER 32	128	128	77,5	77,5	32,2	38,0	135374	162872	135379
7	mi 50	152	152	77,5	77,5	55,0	55,0	173530	162901	105480
9	ER 40	140	140	89,0	89,0	31,0	34,8	105448	162875	162877
9	mi 63	165	165	89,0	89,0	48,3	48,3	169045	162906	162907

**ANSI CAT 50 ZWS**

**Angle Head 90°, Offset Slim Type**

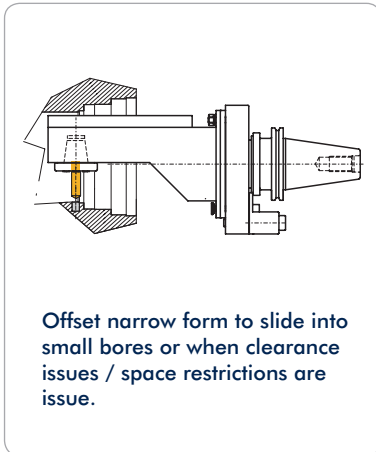

Offset narrow form to slide into small bores or when clearance issues / space restrictions are issue.



**Attention!**  
Reversal of rotation direction

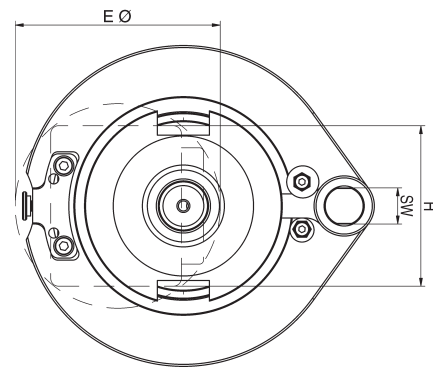
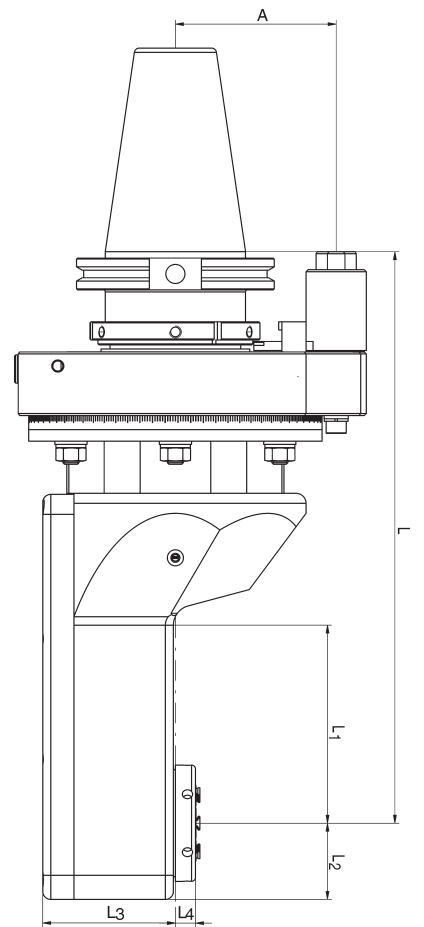

Size	Torque max.	Rev. max. (r.p.m.)	Gear Ratio	L mm	L1 mm	L2 mm	H mm	A mm	kg	SW
0	6 Nm	12.000	i = 1:1,67	227,5	38	20	36	80	11,0	18
5	30 Nm	8.000	i = 1:1	215,0	76	28	56	80	12,5	18
7	70 Nm	6.000	i = 1:1	285,0	100	38	80	80	13,5	18

Size	Toolholder	Clearance dia. E mm		L3 mm		L4 mm		Order No.		
		without coolant	with coolant	without coolant	with coolant	without coolant	with coolant	without coolant	external coolant	internal coolant
0	ER 11	50		49		-8,0		135591		
5	ER 25	82	82	65	65	10,0	10,0	135620	167467	
5	mi 40	125	125	65	65	23,5	23,5	173540	162939	
7	ER 32	102	102	66	66	13,0	13,0	135653	162927	
7	mi 50	135	135	66	66	29,0	29,0	135638	162943	

**ANSI CAT 50 WS**

**Angle Head, Adjustable 0-98°**

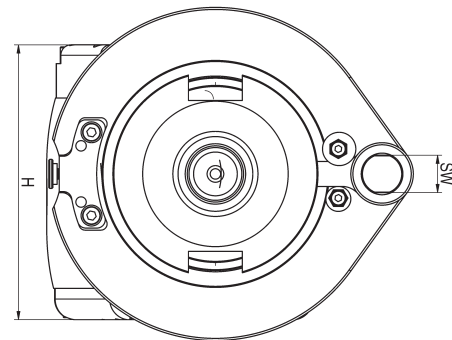
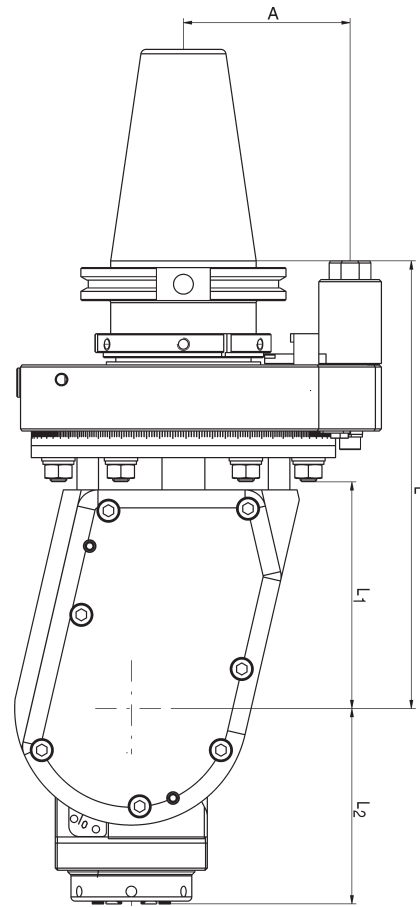
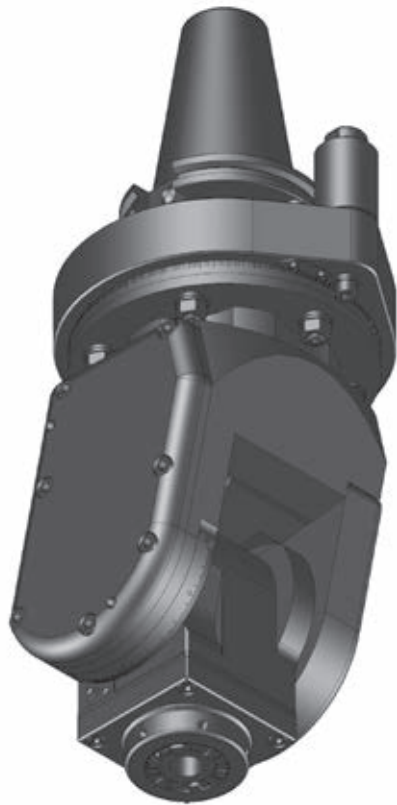
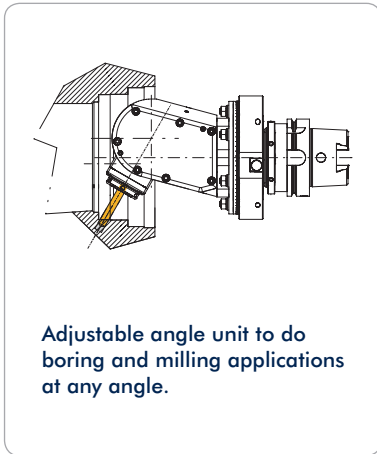

12

Size	Torque max.	Rev. max. (r.p.m.)	Gear Ratio	L mm	L1 mm	H mm	A mm	kg	SW
5	30 Nm	7.000 / 13.500	i = 1:1 / 1:2,25	195	100	111	80	14,0	18
7	70 Nm	6.000	i = 1:1	215	109	132	80	16,0	18

Size	Toolholder	L2 mm	L4 mm	Order No. (i=1:1)		Order No. (i=1:2,25)	
				without coolant	internal coolant	without coolant	internal coolant
5	ER 25	84	25	162946	135839	162947	162948
5	mi 40	97	25	162951	169978	162950	162949
7	ER 32	95	25	162984	162983		
7	mi 50	108	25	162990	169941		

## Checklist for Inquiry

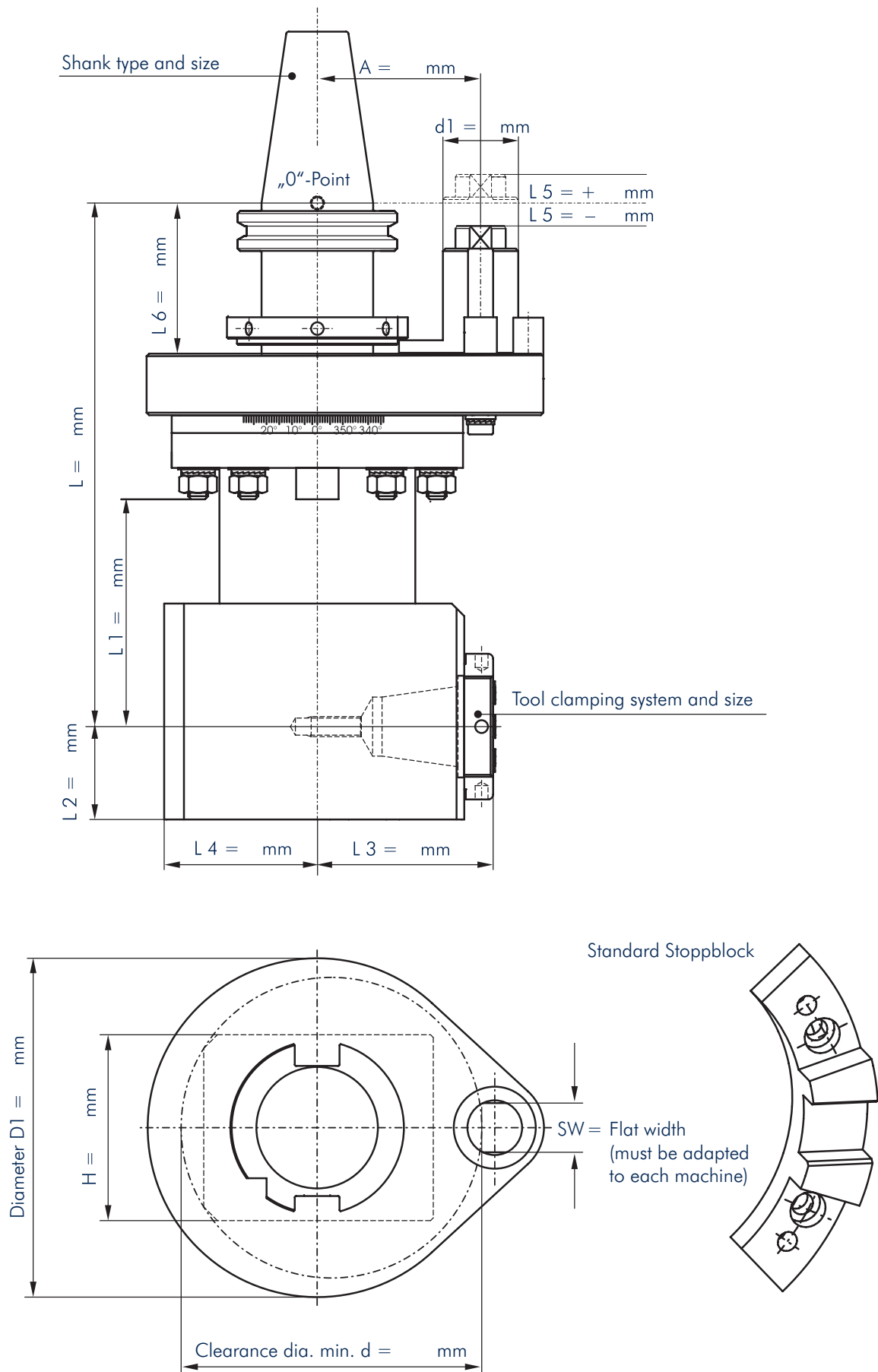

**Form for Inquiry**  
**Fax +49-831-57444-90**

Company	
Name	
Street	
Zip/City	
Phone	
Fax	
E-Mail	

**Specifications to the Machine**

Manufacturer	
Type, Year of manufacturing	
Machine No.	
Coolant pressure (internal coolant)	
Spindle speed max.	r.p.m
max. torque of the spindle	Nm
Support available	yes no
Stop block available	yes no
Stop block drawing	yes (please transmit) no
Tool places (magazine)	pieces

**Specifications to the Operation**

Operation	
(drilling, milling, turning, etc.)	
Material	
Tool	
Work piece drawing	yes (please transmit) no
Number of supports	

**Specifications to the Angle Head**

Spindle connection (Shank)	SK	ANSI-CAT	MAS-BT	HSK
Others				
Shank size (DIN)	others			
Gear ratio	i=			
Dimensions (see drawing page 92)				
Tool holder (One-spindle)				
Another tool holders (Multi-spindle)				
Locking	yes no			
Spindle speed wanted	r.p.m			
Torque moment wanted	Nm			
Offset A	mm			
Locking bolt Ø	mm			
Position to the zero point	+ -		mm	
Tool weight max.	kg			
Tool diameter max.	mm			
Automatic tool change	yes no			
Manual tool change	yes no			
Coolant	yes no			
max. coolant pressure through the spindle (internal)				
Coolant nozzle				
Coolant pipe				
Accessories				

## Modular Angle Heads

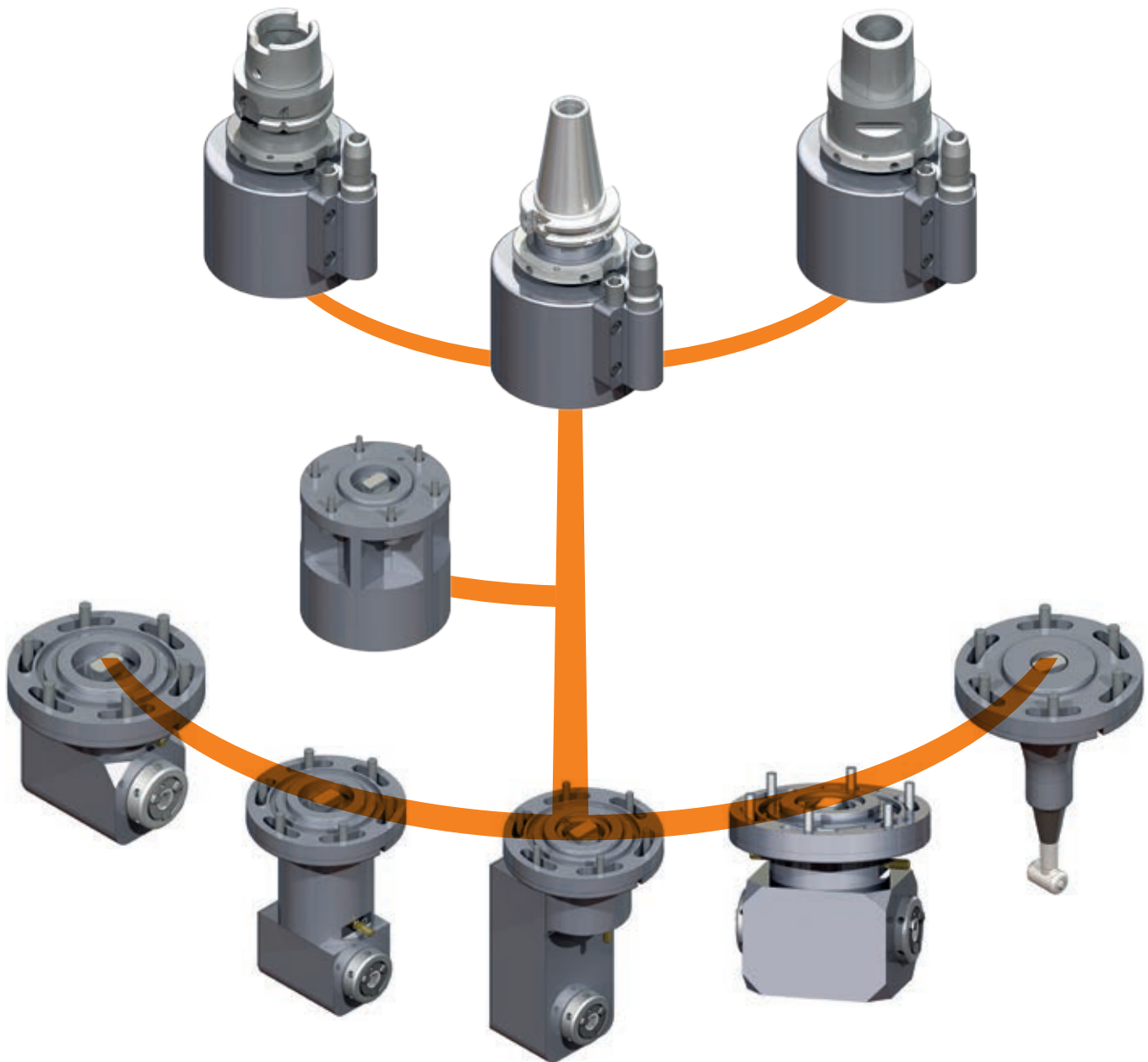

### Modular System

- Flexible for a multitude of applications
- Adaptable with a wide variety of machine tapers
- Bolt design mounting system for added rigidity
- Very cost effective when a variety of angle heads are required
- 360 degree body and head rotation
- Tapered positioning pin for alignment accuracy

### Angle Head Variants

- Compact design (SW) for added milling rigidity
- Extended length (LW) design for added reach
- Slim design (ZWS) for inner bore work
- Double output (DW) design eliminates the necessity for two heads
- NSK output for small internal engraving and light duty milling
- Quick Change system for operations involving multiple tools

# Table of Contents – Modular Angle Heads

Connectable in accordance with **BLUECOMPETENCE** » mimatic mi » PolyMILL » TriMILL » PolyREAM

## Tapers



	HSK-A			HSK-F			DIN 69871			MAS-BT			ANSI CAT			mimatic capto		
Coolant	HSK	ØE mm	Page	HSK	ØE mm	Page	SK	ØE mm		BT	ØE mm	Page	CAT	ØE mm	Page	Capto	ØE mm	Page
✓	63	100	246	80	100	247	40	100	248	40	100	249	40	100	250	C6	100	251
✓	100	100			100			50		100			50	100			50	

## Taper Extension



Coolant	L mm	ØE mm	Page
✓	100	100	254

## Pitch Positioning Pin



Fixation	Coolant	Page
SW 18	✓	252
Cone 20°	✓	253

## Positioning Block

for an exact spindle alignment and as torque support



For taper	Coolant	A mm	Page
40	✓	65	254
50	✓	100	254

## Angle Heads

Selection by Clearance Diameter E and Milling Depth L<sub>1</sub>

### Angle Head 90°

### Angle Head 90° Long Type

### Angle Head 90° Offset Slim Type

### Double Angle Head 90°

### NSK Adapter



Size	Tool holder	Coolant	SW			LW			ZWS			DW			NSK		
			ØE mm	L <sub>1</sub> mm	Page	ØE mm	L <sub>1</sub> mm	Page	ØE mm	L <sub>1</sub> mm	Page	ØE mm	L <sub>1</sub> mm	Page	ØE mm	L <sub>1</sub> mm	Page
0	ER 11		100	45	255	100	100	256	100	110	257			258			259
1	ER 16		100	45		100	100		100	135		100	45		100	133,75	
		✓	100	45		100	100		100	135		100	45				
3	ER 20		100	45		100	100		100	135		100	135				
		✓	100	45		100	100		100	135							
		mi 32		100		45	100		100								
2	ER 25		100	65			100		115	100		165	100		65		
		✓	100	65			100		115	100		165	100		65		
			100	65													
		mi 40	✓	100		65											

## Ordering example

### Ordering example for a complete tool. consisting of:

- Propulsion unit
- Pitch positioning pin
- Angle head



### Tapers

Pages 246-251



### Pitch Positioning Pins

Pages 252-253



### Angle Heads

Pages 255-259

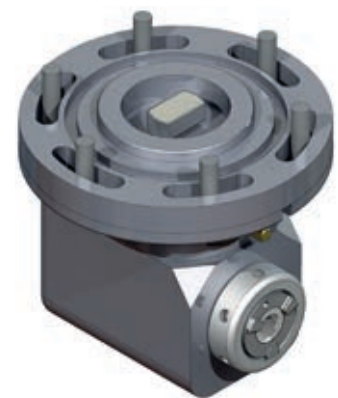



## Coolant

The coolant can be different configurations.

The choice of an internal or external coolant leakage via separate order numbers of the modular angle heads.

### Coolant supply through the spindle



External coolant



Internal coolant

### Coolant supply through the positioning block



External coolant

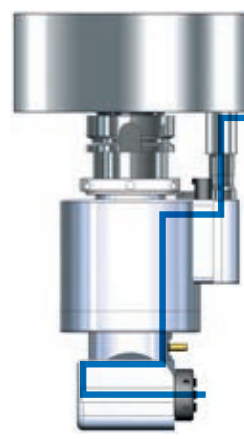

Internal coolant

**HSK-A**

**Tapers for Modular Angle Heads**

- Pitch positioning pins see page 252-253
- Positioning block see page 254

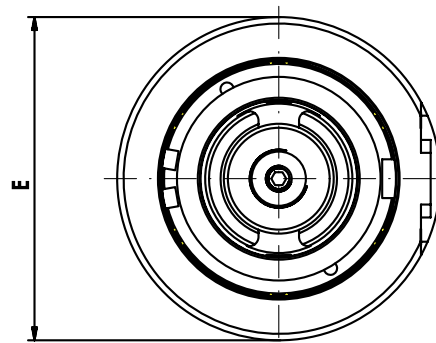
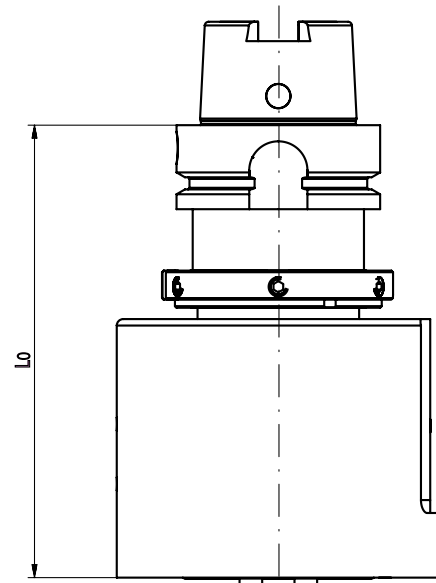

HSK-A	Clearance dia. E mm	L0 mm	Order No.	
			External Coolant	Internal Coolant
63	100	140	162737	162819
100	100	140	162738	162820

**HSK-F**

**Tapers for Modular Angle Heads**

- Pitch positioning pins see page 252-253
- Positioning block see page 254

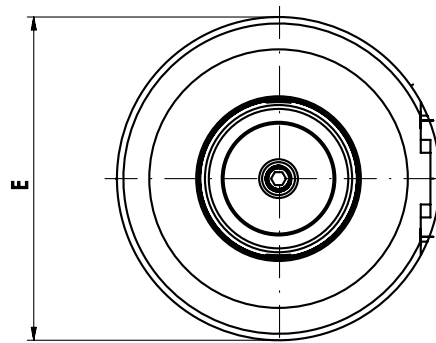
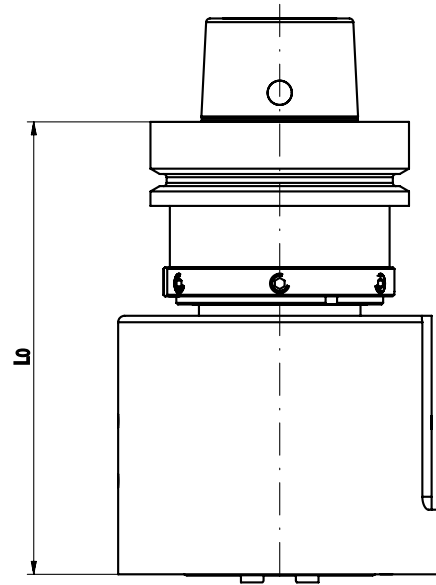

HSK-F	Clearance dia. E mm	L0 mm	Order No.	
			External Coolant	Internal Coolant
80	100	140	162704	

**DIN 69871**

**Tapers for Modular Angle Heads**

- Pitch positioning pins see page 252-253
- Positioning block see page 254

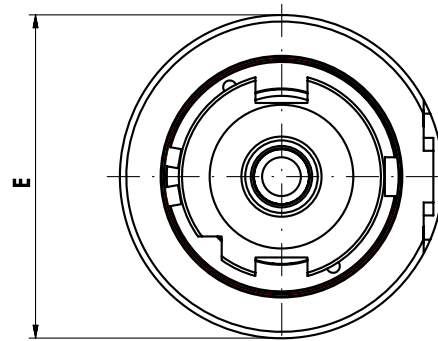
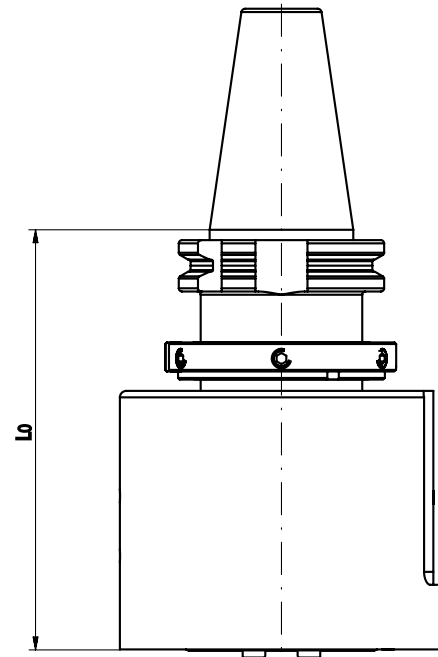

SK	Clearance dia. E mm	L0 mm	Order No.	
			External Coolant	Internal Coolant
40	100	130	162735	162817
50	100	130	162736	162818
50	100	130		

**MAS-BT**

**Tapers for Modular Angle Heads**

- Pitch positioning pins see page 252-253
- Positioning block see page 254

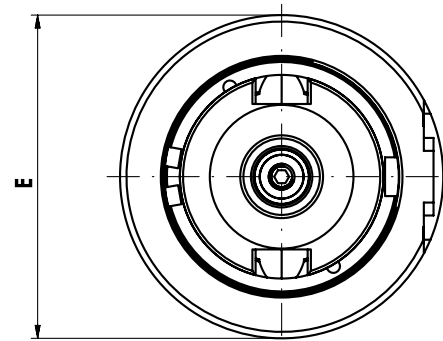
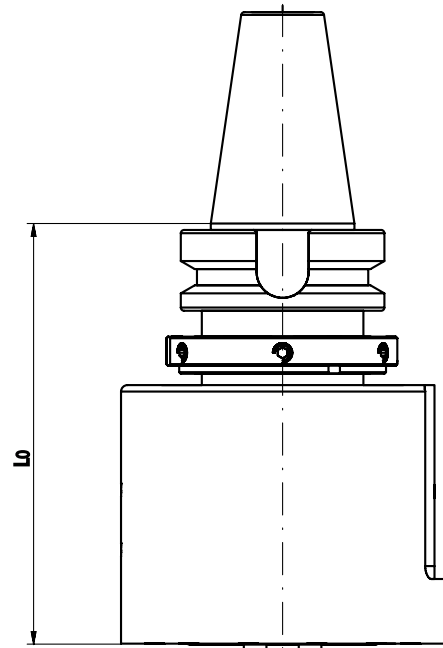

BT	Clearance dia. E mm	L0 mm	Order No.	
			External Coolant	Internal Coolant
40	100	130	162733	162815
50	100	140	162734	162816

**ANSI CAT**

**Tapers for Modular Angle Heads**

- Pitch positioning pins see page 252-253
- Positioning block see page 254

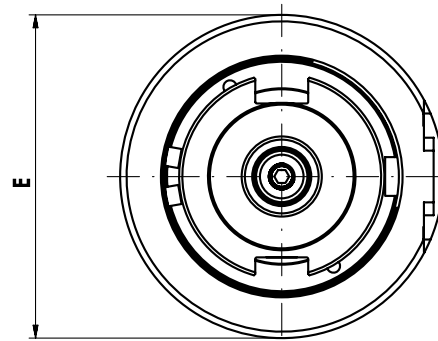
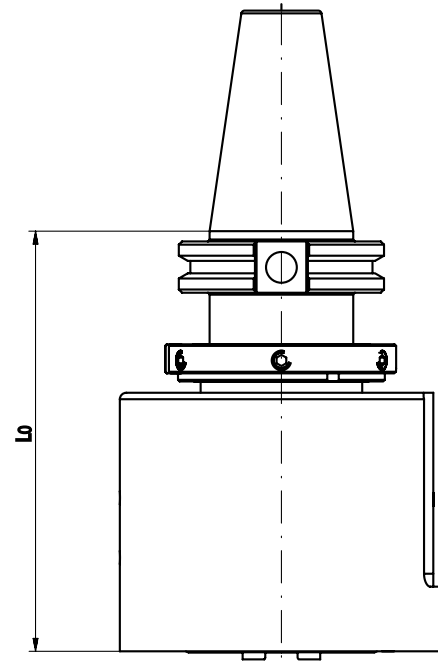

CAT	Clearance dia. E mm	L0 mm	Order No.	
			External Coolant	Internal Coolant
40	100	130	162731	162813
50	100	130	162732	162814
50	100	130		

**mimatic capto**

**Tapers for Modular Angle Heads**

- Pitch positioning pins see page 252-253
- Positioning block see page 254

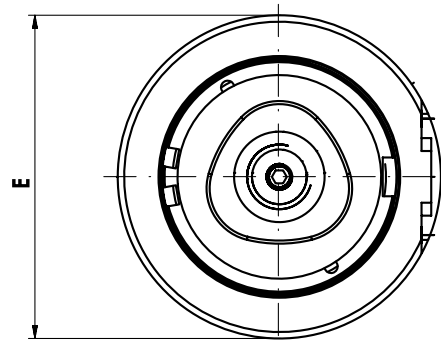
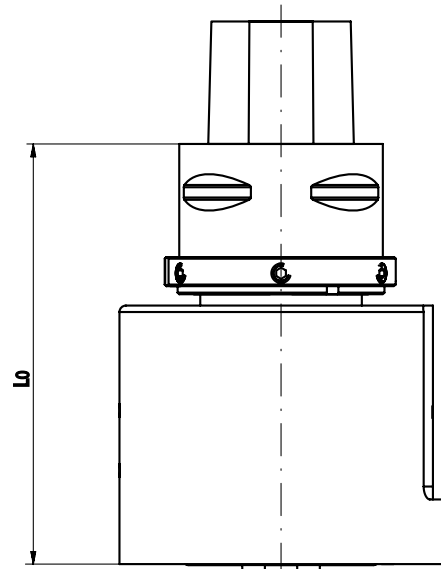

Capto	Clearance dia. E mm	L0 mm	Order No.	
			External Coolant	Internal Coolant
C6	100	130	178043	178044
C8	100	130	162739	162821

## Positioning Pin with SW 18 Fixation

Connectable in accordance with  
**BLUECOMPETENCE** » mimatic mi  
» PolyMILL » TriMILL » PolyREAM

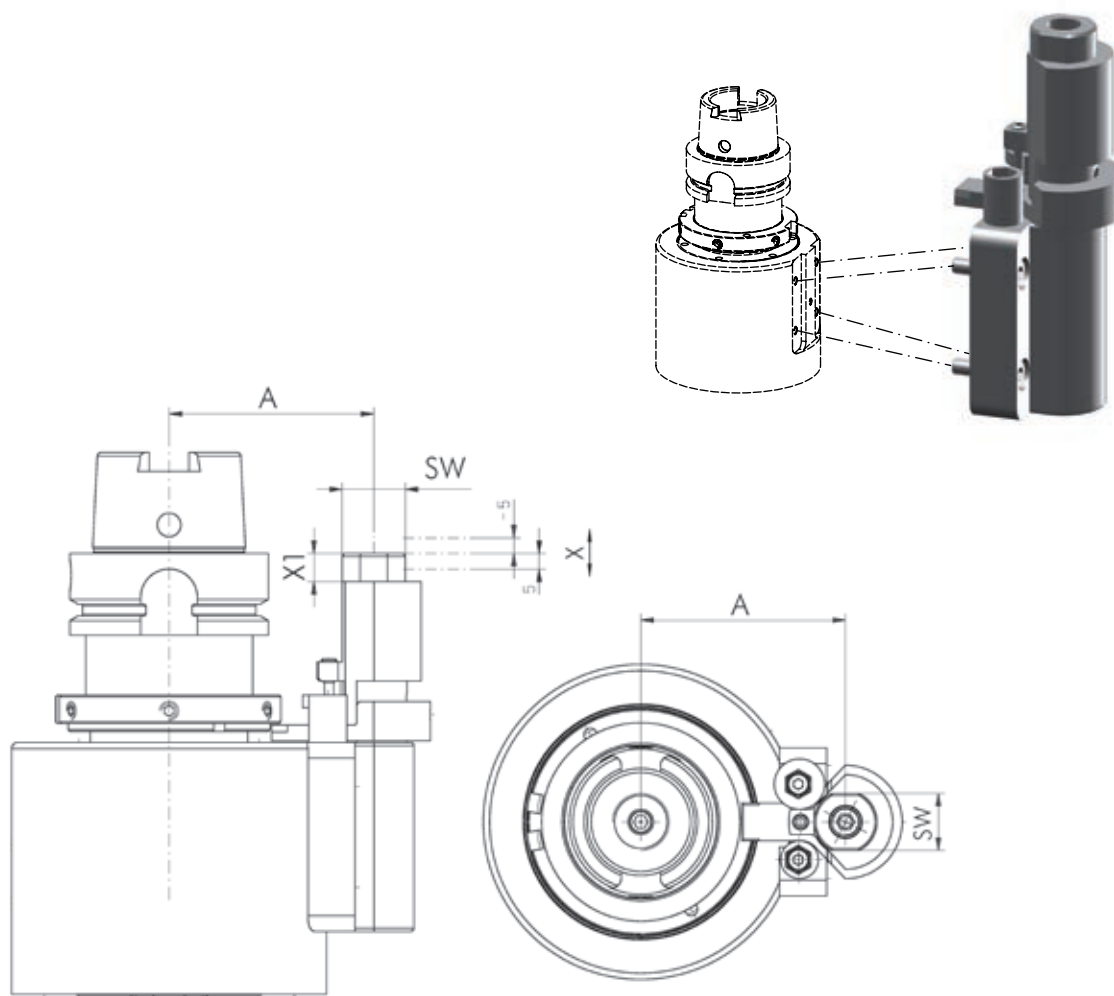

Suitable for Tapers	A mm	X mm (adjustable $\pm 5$ mm)	X1 mm	SW	Order No.
SK 40 / ANSI CAT 40 / BT 40 / C6	65	0	9	18	156683
SK 40 / ANSI CAT 40 / BT 40 / C6	65	12	9	18	156684
HSK 63	65	0	9	18	156685
HSK 63	65	12	9	18	156686
SK 50 / ANSI CAT 50 / C8	80	2	9	18	156687
SK 50 / ANSI CAT 50 / C8	80	12	9	18	156688
HSK 100 / BT 50	80	2	9	18	156691
HSK 100 / BT 50	80	12	9	18	156692



## Positioning Pin with 20° Cone Fixation

Connectable in accordance with **BLUECOMPETENCE** » mimatic mi » PolyMILL » TriMILL » PolyREAM

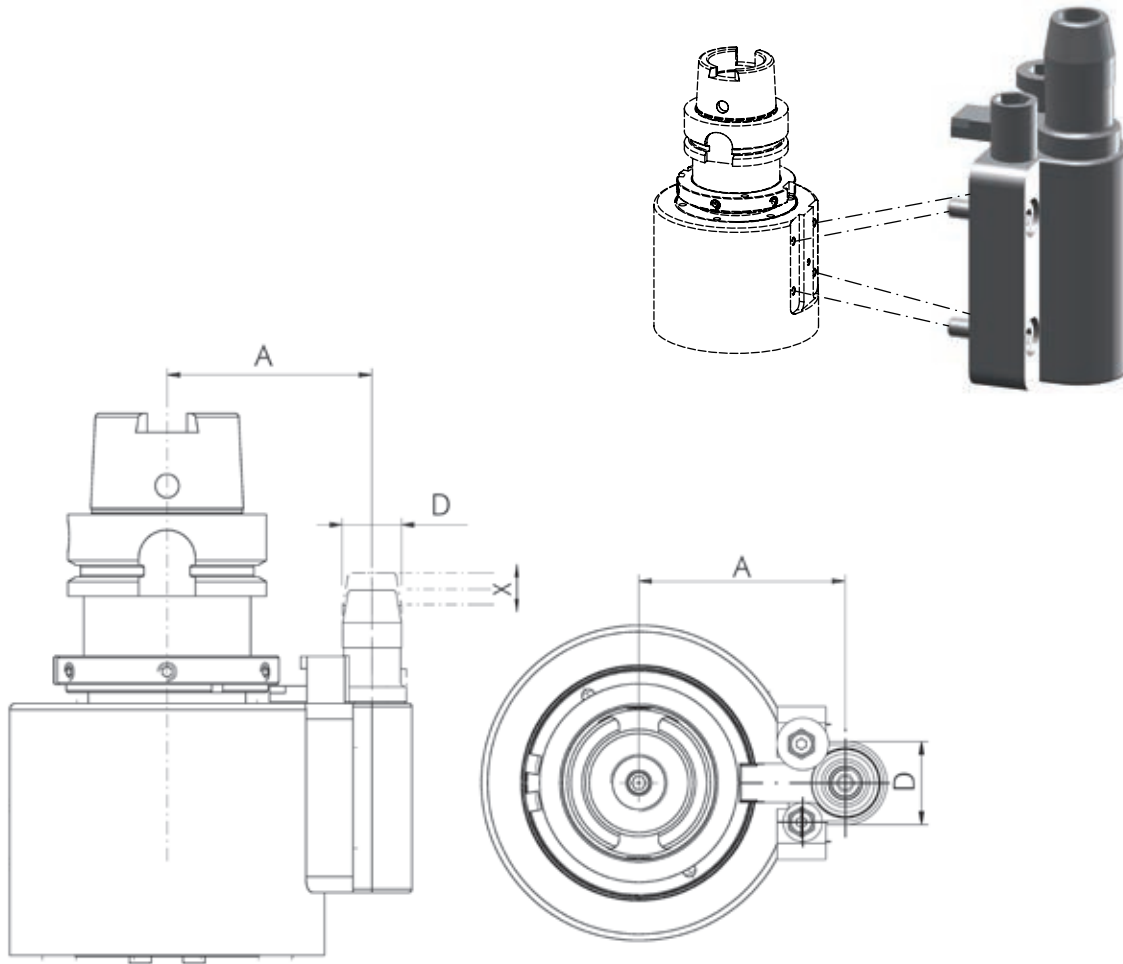

12

Suitable for Tapers	A mm	X mm	D (Pin) mm	Order No.
SK 40 / ANSI CAT 40 / BT 40 / C6	65	14,8	18	162741
SK 40 / ANSI CAT 40 / BT 40 / C6	80	8,3	28	162743
HSK 63	65	14,8	18	162740
SK 50 / ANSI CAT 50 / C8	110	8,3	28	162745
HSK 100 / BT 50	80	8,3	28	162742
HSK 100 / BT 50	110	8,3	28	162744

## Taper Extensions for Modular Angle Heads

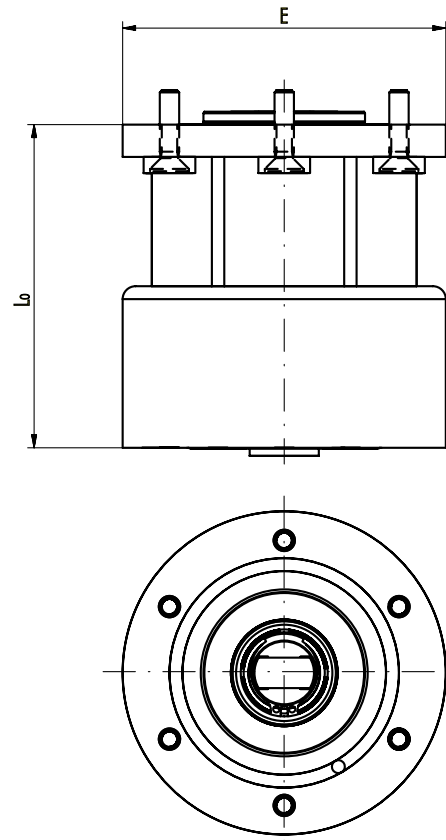

L	Clearance dia. E mm	L <sub>0</sub>	Order No.
75	100	75	162757
100	100	100	162758
200	100	200	162759

## Positioning Block

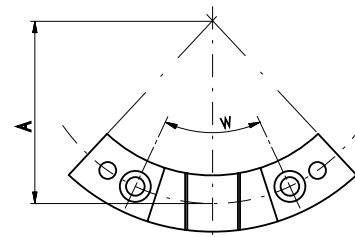
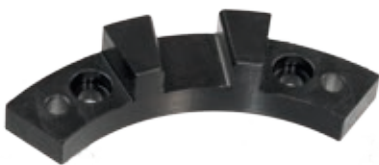

Order No.	A mm	B mm	t mm	H mm	H <sub>1</sub> mm	W mm
135277	65	18	9,5	20	10	50°
135278	80	18	9,5	20	10	45°

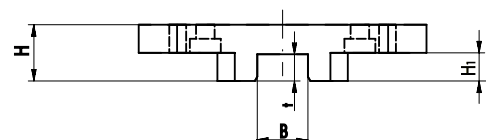

**SW**

Connectable in accordance with **BLUECOMPETENCE** » mimatic mi » PolyMILL » TriMILL » PolyREAM

**Angle Head 90°**

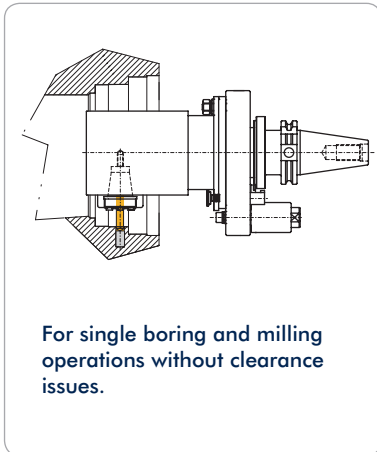

**Attention!**  
Reversal of rotation direction

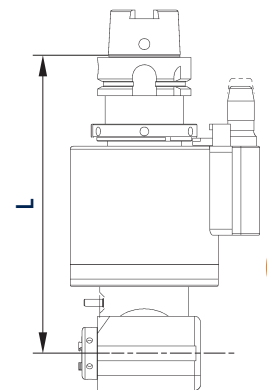
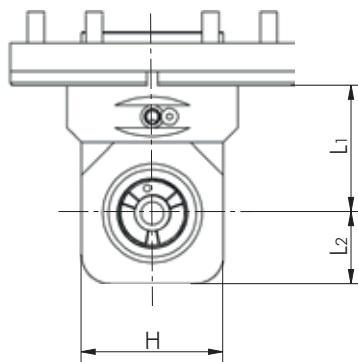
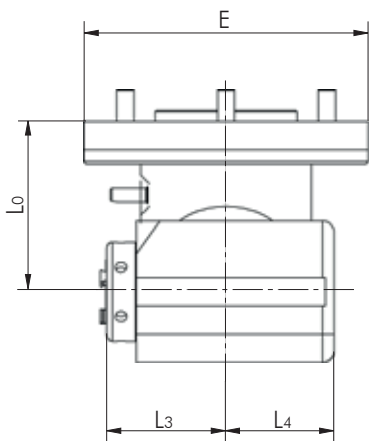

12

Size	Toolholder	Torque max.	Rev. max. (r.p.m.)	L0 mm	L1 mm	L2 mm	L3 mm	L4 mm		H mm	~ kg
								External Coolant	Internal Coolant		
0	ER 11	3 Nm	7.000	60	45	17	34	25	37	40	1,1
1	ER 16	10 Nm	6.000	60	45	25	42	38	50	50	1,4
1	ER 20	10 Nm	6.000	60	45	25	45	38	50	50	1,4
1	mi 32	10 Nm	6.000	60	45	25	59	38	50	50	1,7
2	ER 25	25 Nm	5.000	80	65	35	55	45,5	58	70	2,6
2	mi 40	25 Nm	5.000	80	65	35	71,5	45,5	58	70	3,0

Size	Toolholder	Gear Ratio	Clearance dia. E mm	L mm SK 40,50 / BT 40,50 CAT 40,50 / C6, C8	L mm HSK 63, 80, 100	Order No.	
						External Coolant	Internal Coolant
0	ER 11	i = 1:1	100	190	200	162748	159987
1	ER 16	i = 1:1	100	190	200	162760	162763
1	ER 20	i = 1:1	100	190	200	162749	162889
1	mi 32	i = 1:1	100	190	200	178045	159992
2	ER 25	i = 1:1	100	210	220	162761	162765
2	mi 40	i = 1:1	100	210	220	178047	159994

**LW**

## Angle Head 90°, Long Type

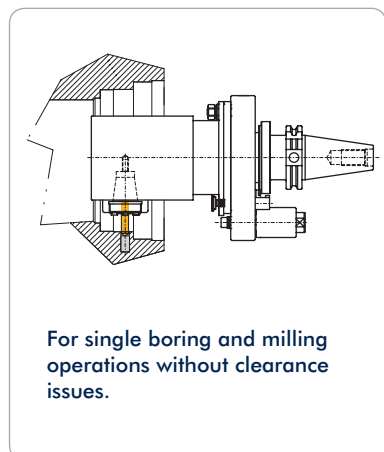

For single boring and milling operations without clearance issues.



**Attention!**  
Reversal of rotation direction

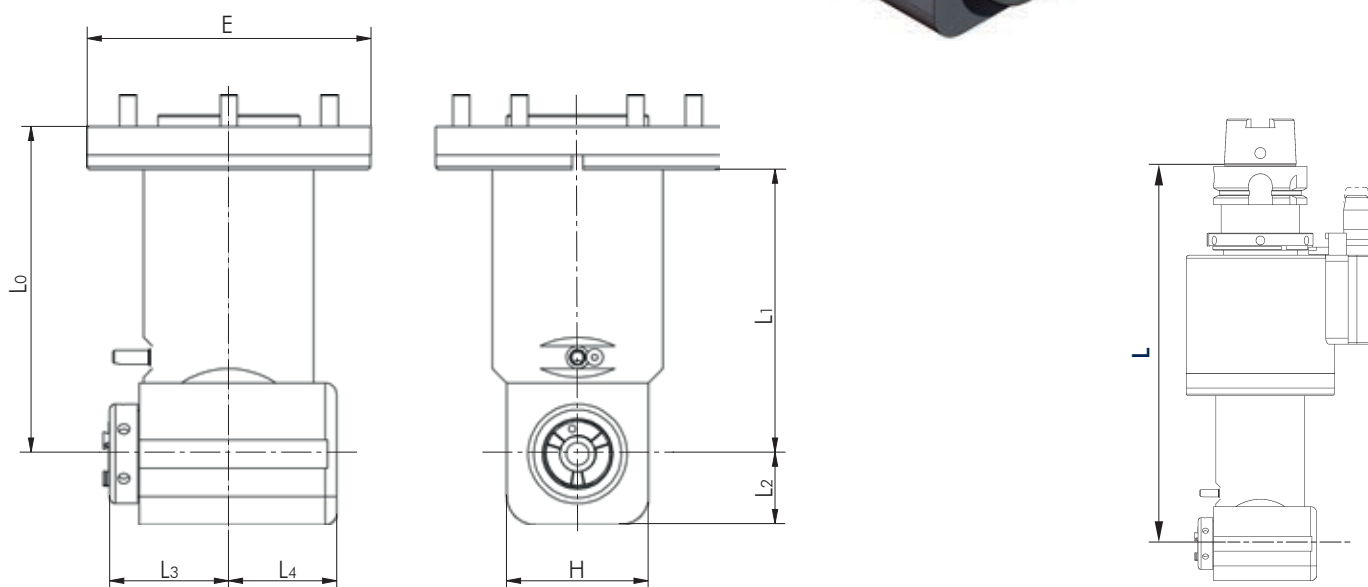
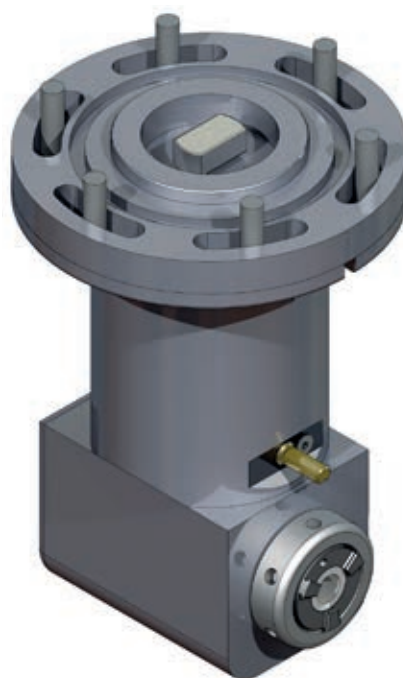

Size	Toolholder	Torque max.	Rev. max. (r.p.m.)	L0 mm	L1 mm	L2 mm	L3 mm	L4 mm External Coolant	Internal Coolant	H mm	~ kg
0	ER 11	3 Nm	7.000	115	100	17	34	25	37	40	1,5
1	ER 16	10 Nm	6.000	115	100	25	42	38	50	50	3,4
1	ER 20	10 Nm	6.000	115	100	25	45	38	50	50	3,6
1	mi 32	10 Nm	6.000	115	100	25	59	38	50	50	3,7
2	ER 25	25 Nm	5.000	130	115	35	55	45,5	58	70	3,2
2	mi 40	25 Nm	5.000	130	115	35	71,5	45,5	58	70	3,6

Size	Toolholder	Gear Ratio	Clearance dia. E mm	L mm SK 40,50 / BT 40,50 CAT 40,50 / C6, C8	L mm HSK 63, 80, 100	Order No.	
						External Coolant	Internal Coolant
0	ER 11	i = 1:1	100	245	255	162706	159988
1	ER 16	i = 1:1	100	245	255	162707	159989
1	ER 20	i = 1:1	100	245	255	162708	159990
1	mi 32	i = 1:1	100	245	255	178046	159993
2	ER 25	i = 1:1	100	260	270	162710	159991
2	mi 40	i = 1:1	100	260	270	178048	159995

**ZWS**

## Angle Head 90°, Offset Slim Type

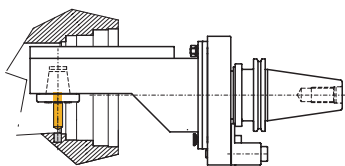

Offset narrow form to slide into small bores or when clearance issues / space restrictions are issue.



**Attention!**  
Reversal of rotation direction

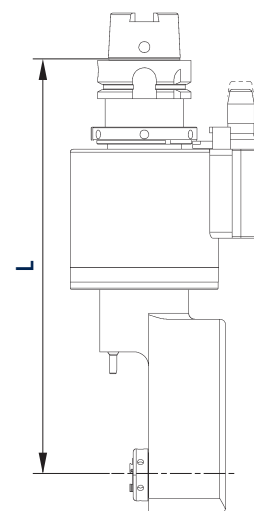
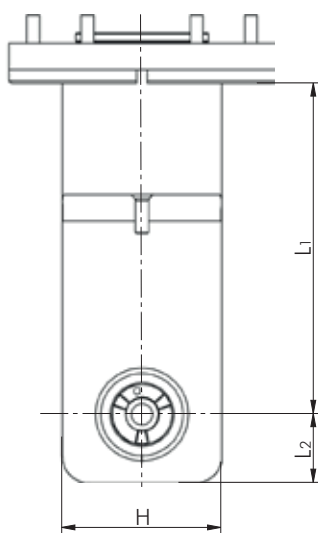
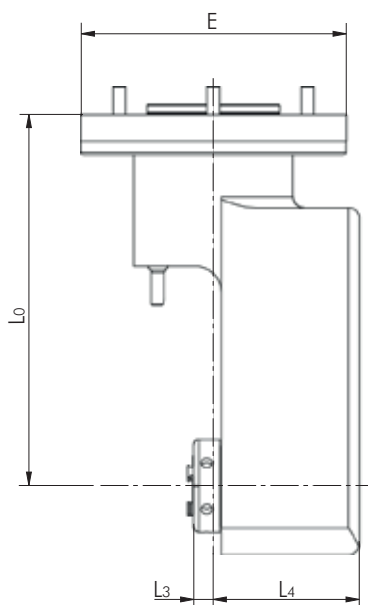
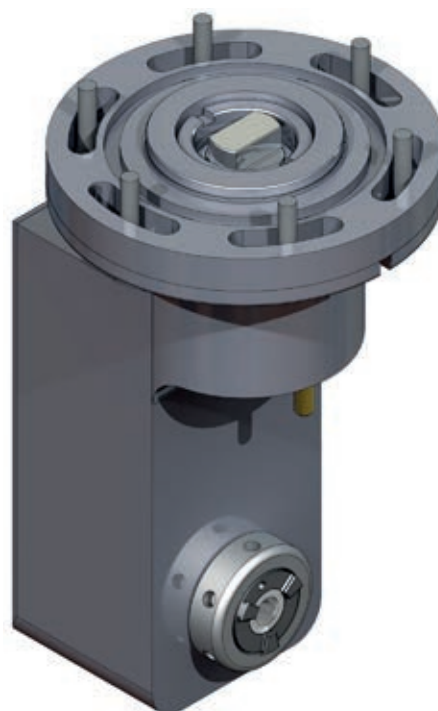

12

Size	Toolholder	Torque max.	Rev. max. (r.p.m.)	L0 mm	L1 mm	L2 mm	L3 mm	L4 mm	H mm	~ kg
0	ER 11	3 Nm	7.000	125	110	195	2,7	42	37	1,5
1	ER 16	10 Nm	6.000	150	135	26	5,0	53	53	2,5
1	ER 20	10 Nm	6.000	150	135	26	9,5	53	53	2,5
2	ER 25	25 Nm	5.000	180	165	29	7,0	67	60	3,5

Size	Toolholder	Gear Ratio	Clearance dia. E mm	L mm		Order No.	
				SK 40,50 / BT 40,50 CAT 40,50 / C6, C8	HSK 63, 80, 100	External Coolant	Internal Coolant
0	ER 11	i = 1:1	100	253	263	162716	
1	ER 16	i = 1:1	100	270	280	162000	
1	ER 20	i = 1:1	100	270	280	162751	
2	ER 25	i = 1:1	100	310	320	178049	

**DW**

**Double Angle Head 90°**

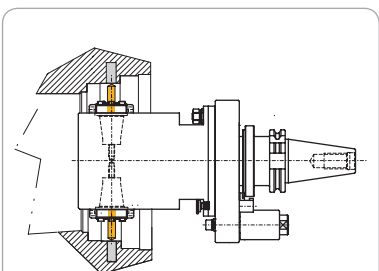

Double spindle unit to do two boring and milling operations in opposite directions.

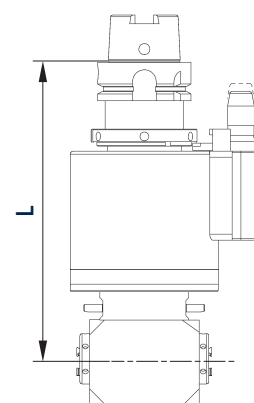
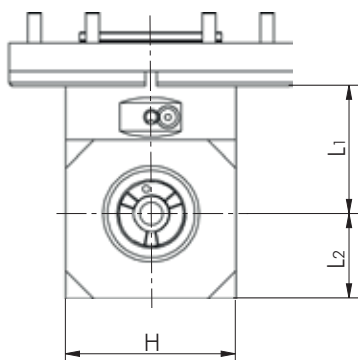
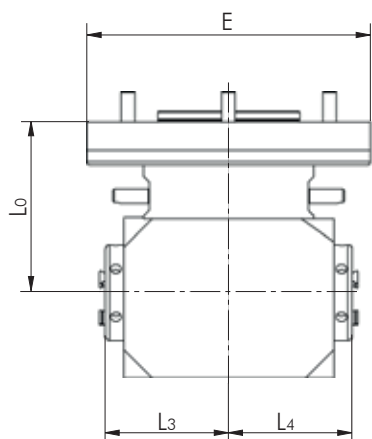
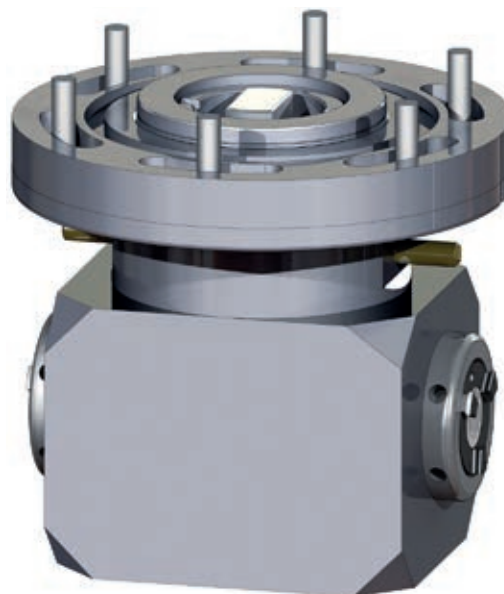

Size	Toolholder	Torque max.	Rev. max. (r.p.m.)	L0 mm	L1 mm	L2 mm	L3 mm	L4 mm	H mm	~ kg
1	ER 16	10 Nm	6.000	60	45	29	43,5	43,5	52	1,8
2	ER 25	30 Nm	5.000	80	65	39	58	58	70	3,2

Size	Toolholder	Gear Ratio	Clearance dia. E mm	L mm		Order No.	
				SK 40,50 / BT 40,50 CAT 40,50 / C6, C8	HSK 63, 80, 100	External Coolant	Internal Coolant
1	ER 16	i = 1:1	100	190	200	162754	
2	ER 25	i = 1:1	100	210	220	162755	

**NSK**

Connectable in accordance with **BLUECOMPETENCE** » mimatic mi » PolyMILL » TriMILL » PolyREAM

## NSK Adapters

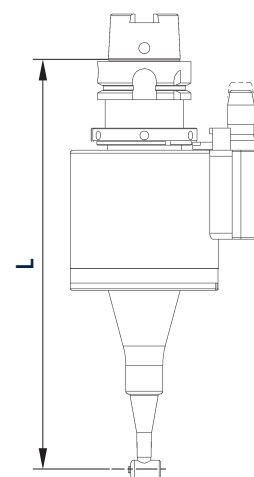
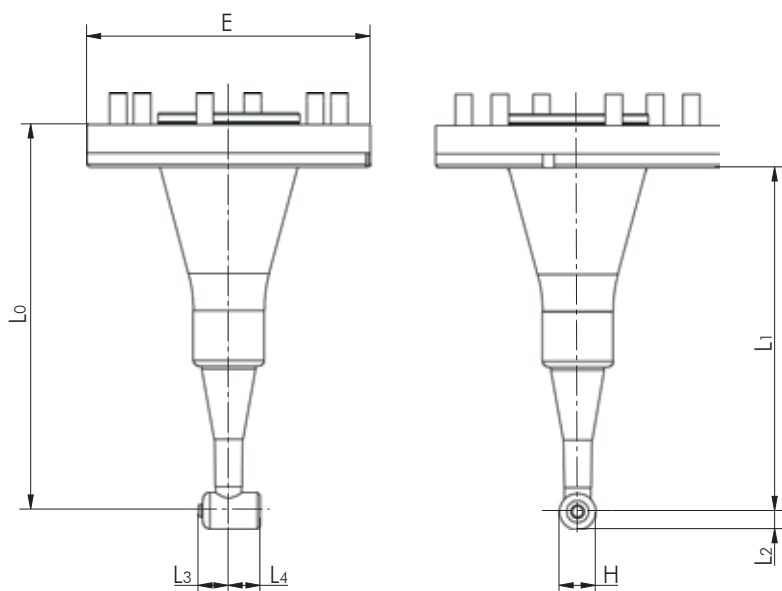

12

Size	Toolholder	Torque max.	Rev. max. (r.p.m.)	L0 mm	L1 mm	L2 mm	L3 mm	L4 mm	Ø H mm	~ kg
1*	NSK - M17	1 Nm	10.000	148,75	133,75	6,35	10,16	10,16	12,7	1,3
1*	NSK - M17	1 Nm	4.255 / 20.000	173,75	158,75	6,35	10,16	10,16	12,7	1,6

Size	Toolholder	Gear Ratio	Clearance dia. E mm	L mm		Order No.	
				SK 40,50 / BT 40,50 CAT 40,50 / C6, C8	HSK 63, 80, 100	External Coolant	Internal Coolant
1*	NSK - M17	i = 1:1	100	266,05	276,05	160250	
1*	NSK - M17	i = 1:4,7	100	291,05	301,05	160251	

\* Units comes standard with NSK model # IC-300